

INTREPID

BERGEN

GAS EB

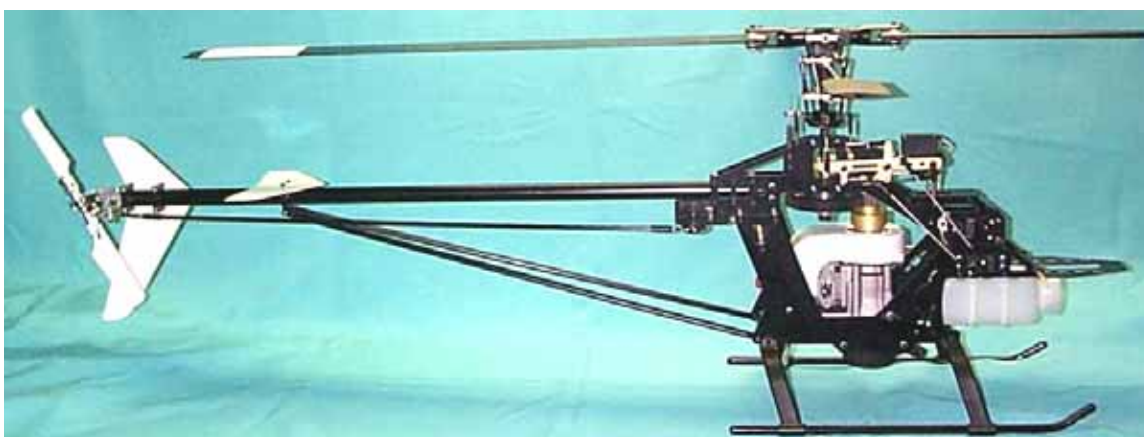

INTREPID GAS EB

Owners Manual

Assembly Instructions

Rev. 1

INTREPID GAS EB

Table Of Contents

PARTS LIST	9
LOWER FRAMES	14
BATTERY TRAY	15
LANDING GEAR ASSEMBLY AND MOUNTING.....	16
FAN AND SHROUD ASSEMBLY	17
STARTER MOUNTING.....	19
CLUTCH BUSHING INSTALLATION.....	20
ENGINE MOUNTING.....	21
THROTTLE ARM	23
MOUNT LOWER SERVOS	24
MOUNT COLLECTIVE BEARINGS	25
LEFT UPPER FRAME ASSEMBLY	26
MAIN GEAR ASSEMBLY	27
ELEVATOR YOKE ASSEMBLY	28
TAIL TRANSMISSION ASSEMBLY	29
CLUTCH INSTALLATION	30
MAIN SHAFT ASSEMBLY.....	31
MAIN SHAFT AND MAIN GEAR INSTALLATION	32
TAIL TRANSMISSION INSTALLATION.....	33
COLLECTIVE AXLES.....	34
UPPER FRAME ASSEMBLY.....	35
UPPER RIGHT SIDEFAME INSTALLATION	36
TORQUE TUBE	Error! Bookmark not defined.
TAILBOOM ASSEMBLY	Error! Bookmark not defined.
GYRO TRAY AND BATTERY MONITOR	38
CONTROL ARMS.....	39
COLLECTIVE ARMS	41
COLLECTIVE ARM INSTALLATION.....	42
COLLECTIVE BELLCRANK INSTALLATION.....	43
SERVO ARMS AND LINKAGES	44
AILERON SERVO	46
AILERON SERVO INSTALLATION.....	48
AILERON PUSHRODS	49
COLLECTIVE SERVO WHEEL.....	50
PRIMARY COLLECTIVE PUSHRODS.....	51
SECONDARY COLLECTIVE PUSHRODS	52
ELEVATOR PUSHRODS	53
ELEVATOR SERVO AND PUSHRODS.....	54
THROTTLE LINKAGE.....	56
SWASHPLATE.....	58
LOWER SWASHPLATE LINKAGES.....	59
WASHOUT ASSEMBLY	60
SEESAW TUBE ASSEMBLY.....	62
HEAD BLOCK	63
BLADE GRIP ASSEMBLY	65
BLADE GRIP ATTACHMENT	66
FLYBAR	67
HEAD ATTACHMENT.....	68
HILLER PUSHRODS	69
BELL PUSHRODS	70
WASHOUT ARM LINKS	71
TAIL ROTOR GRIPS	72
TAIL PITCH ASSEMBLY	76
PITCH BELLCRANK.....	77
TAIL BLADES	78

RUDDER SERVO.....	79
TAILBOOM SUPPORT STRUTS.....	82
RUDDER PUSHROD.....	83
FINS.....	84
FUEL TANK.....	85
CANOPY.....	87
FINAL ADJUSTMENTS.....	89
ENGINE BREAK-IN.....	90



WARNING!



The radio controlled model helicopter built from this kit is not a toy and is not meant for children. It is a flying machine capable of causing property damage and serious bodily harm to both the operator/assembler and/or spectator if not built and operated correctly and responsibly. Rotating components, especially the main rotor blades, are an ever-present danger.

Model helicopters operate differently than model cars and airplanes. Helicopters by their nature are not positively stable, meaning that even if properly assembled and adjusted, helicopters will not recover from an unwanted flight attitude, nor will they hold any particular orientation without constant control inputs from the pilot.

IT IS YOUR EXCLUSIVE RESPONSIBILITY TO PROPERLY BUILD, MAINTAIN AND OPERATE THIS HELICOPTER. Bergen R/C Helicopters has spent considerable time making this product reliable and easy to build, but only the operator can insure that it is safe. Because the safe operation of this helicopter is beyond the control of the Manufacturer and distributor, the owner/operator assumes all risk of use.

Construction Manual
Acknowledgments

Bergen R/C Helicopters wishes to thank the facilities and friends for their continuing support during the development of the Intrepid Helicopter.

Staff

Chris Bergen; Chief Executive Officer
Larry Bergen; Chief Design Engineer and General Manager
Mary Ann Pratt; Marketing Sales and Service
Terri Demeyer; Office Management
Mike Bergen; Programmer, Engineer
Larry Mihills; Machinist
Malorie Zastrow and Gary Travis; Test Pilot/Engineer

Bergen R/C Helicopters LLC
1101 Follett Drive
Cassopolis, MI 49031
Voice: (269) 445-2060
Fax: (269) 445-2250
Web: bergenrc.com
Email: bergenrc@verizon.net

Introduction

The first of its kind, interchangeable modular engineered helicopter to accommodate the beginner to a FAI expert...

An idea in 1994 to manufacture an interchangeable, modular helicopter, led to the research and development in 1995. Focusing on quality, engineering details, and price, a prototype was produced. After extensive test flights and fine-tuning, the INTREPID HELICOPTER is now what you see today. The first of its kind, strength combined with simplicity for easy maintenance and flying.

Although beginners can successfully build and fly their INTREPID, the process can be made significantly easier with the help of an experienced modeler and instructor pilot. We recommend that all beginners join the Academy of Model Aeronautics (AMA). The AMA is a non-profit organization that provides services for modelers. The AMA can help you locate a model aircraft club in your area with an instructor pilot (you can also check with your local hobby shop). Membership benefits include a monthly magazine and liability insurance. Many flying clubs require an AMA modeler's license to operate a model on their flying field. For more information on the AMA contact:



*Academy of Model Aeronautics
5151 East Memorial Drive
Muncie, IN 47302
Phone: (317) 287-1256*

Consumer Warranty

IMPORTANT! Before building the **INTREPID GAS** Helicopter kit, read and fully understand the following warranty, and review the entire Construction Manual. By building and/or flying this helicopter you indicate your acceptance of the following warranty terms and conditions, and further agree to build and operate this helicopter in safe and responsible manner.

If you find any term or condition unacceptable, or if you feel that this helicopter is just not suited to you, you may return it to your place of purchase in NEW and UNUSED condition within thirty (30) days of the date of purchase for a refund of the purchase price less shipping and handling. Partially assembled kits, and kits with opened parts packs or missing parts cannot be returned for a refund.

Warranty:

1. Bergen warrants to the first consumer Purchaser that the INTREPID GAS helicopter substantially conforms to its published description when used as intended as a hobby product, and will be free from defects in materials and workmanship for a period of 90 days after the date of purchase. Bergen R/C will repair or replace (at his option) any defective part, and supply any missing part at no charge to the Purchaser within this period. We make no warranty, express or implied. This warranty does not apply to parts damaged by improper assembly, modification, abnormal service or handling, or crashes.
2. To take advantage of this warranty, the Purchaser must provide proof of purchase, and ship any defective part (at Purchaser's cost) to Bergen R/C for repair or replacement.
3. It is the responsibility of the Purchaser to properly assemble, maintain and operate this helicopter in accordance with manufacture's instructions, AMA safety codes, local laws and ordinances, and COMMON SENSE. It is also the responsibility of the Purchaser, when operating this helicopter, never to operate it in any way, which might endanger persons or property including the Purchaser. Purchaser is advised to carry appropriate liability insurance such as that commonly provided to modelers by the AMA.
4. **THIS WARRANTY SPECIFICALLY EXCLUDES THE IMPLIED WARRANTIES OF MERCHANTABILITY AND FITNESS FOR A PARTICULAR PURPOSE.** The selection of this helicopter for a particular application or use (beyond hobby/entertainment) is the sole responsibility of the Purchaser. Any advice supplied by any representative of Bergen R/C pertaining to any particular application is given freely as an opinion and is not meant to bind Bergen R/C or in any other way modify this warranty.

1. Notwithstanding the paragraph above, this warranty is in addition to whatever implied warranties may be granted to the Purchaser by law. To the extent permitted by law, all implied warranties, including the warranties of merchantability and fitness for a particular purpose are limited to a period of (1) year from the date of purchase. Some states do not allow limitations on how long an implied warranty last, so the above limitation may not apply.
2. This warranty shall be the sole and exclusive remedy available to the Purchaser. Correction of defects, in the manner and for the period of time specified above, shall constitute complete fulfillment of all liabilities and responsibilities of Bergen to the Purchaser, and shall constitute full satisfaction of all claims, whether based on contract, negligence, strict liability or otherwise. Bergen R/C shall not be liable for any cost or expenses incurred in; the replacement of any effective or non-conforming parts, and **IN NO EVENT SHALL BERGEN R/C BE LIABLE FOR INCIDENTAL OR CONSEQUENTIAL DAMAGES, OR ANY DAMAGES DUE TO THE USE OR INABILITY TO USE THIS PRODUCT.** Bergen R/C shall not be liable, or in any way responsible, for any damages related to modifications, repairs, attempted repairs, or crashes. **IN NO EVENT SHALL BERGEN R/C's OBLIGATIONS TO THE PURCHASER EXCEED THE ORIGINAL PURCHASE PRICE PAID BY THE PURCHASER.**
3. Some states do not allow exclusion of incidental or consequential damages, so the above exclusion may not apply. This warranty gives the Purchaser specific legal rights. The Purchaser may also have other rights, which vary, from state to state.
4. No modification or amendment to this warranty will be effective unless reduced to writing and signed by an authorized representative of Bergen R/C Distributorship.

If you do not understand any aspect of this warranty, you may contact Bergen R/C Helicopters for clarification. **IF YOU DO NOT AGREE WITH ANY ASPECT OF THIS WARRANTY, RETURN THE UNASSEMBLED HELICOPTER TO YOUR MANUFACTURER FOR A REFUND.**

Bergen R/C Helicopters believes that information contained within its published materials is accurate as of the date of publication, and is not responsible for inadvertent errors or omissions. Bergen R/C reserves the right to make changes and improvements in its products without notice.

PARTS LIST

INTREPID GAS TORQUE TUBE DRIVE

BAG 1

1	1506	LOWER FRAME (RIGHT)
1	1507	LOWER FRAME (LEFT)
10	5175	29M FRAME SPACERS
10	5055	3X40M SHCS
2	1560	SKID BAR – GAS
10	5090	3X8M FHCS
1	1517	BATTERY TRAY – EXTENDED GAS
2	1530	BATTERY TRAY SPACER – GAS
4	5010	3X8M SHCS
4	1945	CANOPY GROMMET
2	1931	STANDOFF LONG
2	1933	STANDOFF SHORT 24MM FOR LEXAN CANOPY
2	5102	3X12M SET SCREW
2	5010	3X8M SHCS
4	1946	THUMB SCREWS (INCLUDES...)
4	5015	3X10M SHCS
4	1946A	THUMB SCREW CAP

BAG 2

1	1574	LANDING GEAR SET (BLACK OR WHITE)
2	5206	SELF TAPPING SCREWS
4	5030	3X16M SHCS
4	5105	3M LOCK NUTS

BAG 3

1	1880	FUEL TANK - GAS
1	1850	CLUNK
1	1855	SINGLE END FITTING
1	1860	DOUBLE END FITTING
2	1865	FUEL TANK NUTS
1	1915	FUEL TUBING – GAS 24"

BAG 4

1	1415	FAN ASSEMBLY – GAS
1	1455	FAN SHROUD - GAS
1	1460	FAN SHROUD MOUNT
4	5085	5X12M SHCS
3	5091	5X12 FHCS
4	5060	4X12M SHCS
4	5230	3X16M SHCS
4	5105	3M LOCKNUTS
1	5130	¼ LOCK WASHER
1	5086	6X25M SHCS
2	5095	3X4M SET SCREWS
3	5065	4X16M SHCS
4	5010	3X8M SHCS
2	5015	3X10M SHCS
1	1470	MOTOR MOUNT BRACKET – GAS
2	2040	MOTOR MOUNT SPACER – GAS
2	5069	5X65M SHCS (MUFFLER BOLTS)
2	5110	3M FLAT WASHERS
1	2045	THROTTLE ARM – GAS
1	2030	MUFFLER SPACER – GAS
3	5109	4M FLAT WASHER
1	2036	PULL START ADAPTOR
1	5190	SHORT BALL

1	1980	140M THROTTLE LINKAGE
4	5141	3X18M SHCS
4	5105	3M LOCKNUTS
8	231B	SPECIAL WASHERS
		BAG 5
2	1475	UPPER FRAME
4	3034	6X12X4F BEARING
2	1620	COLLECTIVE AXLE
5	5170	26M FRAME SPACER
1	1250	MAIN SHAFT BEARING BLOCK ASSEMBLY
2	5190	SHORT BALLS
4	5050	3X35M SHCS
4	5001	3X4M SHCS
4	5105	3M LOCK NUT
2	5110	3M WASHER
1	280	ELEVATOR CONTROL YOKE ASSY
1	1600	ELEVATOR CONTROL SHAFT LONG
1	1605	ELEVATOR CONTROL SHAFT SHORT
2	5015	3X10M SHCS
1	1832	VERTICAL FIN
1	1835	HORIZONTAL FIN
1	1535	RUDDER SERVO MOUNT
		BAG 6
1	1233	MAIN SHAFT ASSEMBLY
2	1245	SPLIT MAIN SHAFT COLLAR ASSEMBLY
1	1265	AUTO HUB ASSEMBLY
4	5015	3X10M SHCS
4	5110	3M WASHERS
1	1307	CLUTCH BELL ASSEMBLY – GAS W/12 TOOTH PINION
1	1276	CLUTCH ASSEMBLY - GAS
1	1260	START SHAFT BEARING ASSEMBLY (TRIPLE BEARING BLOCK)
2	1295	DELFIN BUSHING
2	1300	STEEL INSERT
2	5065	4X16M SHCS
4	5308	3X8 SPECIAL LOW HEAD CAP SCREWS
1	1270	MAIN GEAR
1	6mm	COLLAR
		BAG 7
2	1616	COLLECTIVE ARM
1	1625	COLLECTIVE BELLCRANK TRIPLE
1	1630	COLLECTIVE BELLCRANK SINGLE
4	5200	LONG BALLS
20	5010	3X8M SHCS
5	5110	3M WASHERS
1	1540	AILERON SERVO MOUNT
2	1641	AILERON BELL CRANK
8	3031	5X8X2.5FBEARING
12	5190	SHORT BALLS
3	1645	CONTROL ARM JAMNUT
2	5030	3X16M SHCS
1	1651	ELEVATOR X CONTROL ARM
1	5035	3X20M SHCS
1	1610	ELEVATOR CONTROL ARM
1	1545	GYRO MOUNT
1	1550	BATTERY MONITOR MOUNT
2	1546	GYRO MOUNT BLOCK 3 HOLE
1	5090	3X8M FHSCS

BAG 8

1	1155	SEESAW TUBE
2	1160	SEESAW END CAPS
2	3020	4X10X4 BEARING
2	1165	4M WASHER (SPECIAL)
4	5095	3X4M SET SCREW
2	1175	FLYBAR CONTROL ARM
2	1181	FLYBAR PADDLE
6	5190	SHORT BALL
4	5155	3M BRASS WASHER
2	3015	3X10X4 BEARING
2	5205	3X5M PAN HEAD SCREW
2	1151	BELL MIXER ARM
4	3086	3X7X3F BEARING
2	5136	3X12M W/6M SHOULDER SHCS
2	5115	3M NUT
1	1106	HEAD BLOCK
2	1111	BLADE GRIP ASSEMBLY W/BEARING INSTALLED
2	1126	BLADE GRIP PITCH ARM
2	3006	8X16X5 THRUST BEARING
1	1131	HEAD AXLE WITH C-CLIPS
4	1135	DAMPENING O'RING
2	1140	8MX.015 SHIM DAMPENING WASHER
2	1145	8MX.008 SHIM DAMPENING WASHER
2	1147	8X1M SHIM DAMPENING WASHER
2	5150	4X25M SHCS SPECIAL W/18M SHOULDER
2	5106	4M LOCK NUT
4	5005	3X6M SHCS FOR BLADE PITCH ARM TO GRIP
2	5010	3X8M SHCS FOR SEESAW TUBE
2	5030	3X16M SHCS
1	5035	3X20M SHCS
2	5072	5X16M SHCS
2	5111	5X10X2 SPACER WASHER

BAG 9

1	1185	WASHOUT HUB ASSEMBLY
2	1201	WASHOUT MIXING ARM
4	3086	3X7X3F BEARING
2	5140	3X16M SPECIAL SHCS
2	5155	3M BRASS WASHER
4	5095	3X4M SET SCREW
2	1205	RADIUS LINK
2	1210	RADIUS LINK PIN
5	5190	SHORT BALL
1	1215	SWASH PLATE ASSEMBLY
4	5195	MEDIUM BALL

BAG 10A ASSEMBLY 1

TAIL ROTOR BLADE GRIPS #231

1	TWIN1815	TAIL ROTOR MAIN HUB 6M
2	230A	BLADE GRIP
4	3054	5X10X4 BEARING
2	3052	5X10X4 THRUST BEARING
2	5110	3M FLAT WASHER
2	5015	3X6 SHCS
2	5146	3X19 W/11 SHOULDER SHCS
2	5112	10M OD SPACER

2	5105	3M LOCK NUT
1	5094	3X4M SET SCREW

ASSEMBLY 2
PITCH BELLCRANK #240

1	240B	BELLCRANK
1	240A	DELRIN INSERT
1	240C	ALUMINUM SPACER
2	3086	3X7X3 FLANGE BEARING
1	5140	3X16 W/6 SHOULDER SHCS
2	5155	3M BRASS WASHER
1	5195	MEDIUM BALL
1	5105	3M LOCKNUT

ASSEMBLY 3
PITCH SLIDER #TWIN1960

1	TWIN1786	PITCH SLIDER HUB
1	TWIN1792	PITCH SLIDER TUBE (NEW)
1	TWIN1793	PITCH SLIDER SPACER (THICK)
1	TWIN1794	PITCH SLIDER SPACER (THIN)
2	3036	6X10X3 FLANGE BEARING
1	TWIN1801	ALUMINUM PITCH PLATE
2	5137	5X2M BALL
2	5076	2X8M SHCS
2	5120	2M NUT
2	1961	TAIL SPECIAL BALL LINKS
2	1806	PIVOT PLATE ARM EYELET
2	1811	PIVOT PLATE SHOULDER BOLT 4x4

ASSEMBLY 4
ALUMINUM TAIL ROTOR GEAR BOX #TWIN1000

1	TWIN1000	GEAR BOX ONLY
1	5094	3X3M SET SCREW
2	5095	3X4M SET SCREW
1	TWIN1000B	PITCH ARM BRACKET
1	TWIN1000C	ALUMINUM SPACER
1	3071	10X15X4 FLANGE BEARING
3	3055	5X13X4 BEARING
1	1000E	10M PIN
1	1210	12M PIN
1	TWIN 1000F	TAIL GEAR SET
1	TWIN 1000I	INPUT SHAFT FOR GEAR BOX
1	TWIN 1000D	OUTPUT SHAFT FOR BLADE GRIPS
1	TWIN 1000J	BRASS SPACER TUBE
1	5025	3X5 PAN HEAD SCREW
2	5001	3X4 SHCS
2	5090	3X8 FLAT HEAD CAP SCREWS

ASSEMBLY 5

5 SETS	TWIN 1665	TAILBOOM CLAMPS
1	TWIN 1667	HORIZONTAL FIN CLAMP

ASSEMBLY 6
UNIVERSAL JOINT #9000

1	9010	DELRIN COUPLER
1	9005	OUTPUT SHAFT

1	9015	DOGBONE
1	9020	DOGBONE PIN
1	1210	COUPLER PIN
2	5095	3X4 SET SCREWS

MISC BAG

4	109D	COLLARS FOR TORQUE TUBE DRIVE
8	5050	3X35 SHCS
3	5055	3X40 SHCS
10	5110	3M WASHERS (TRANS BEAR BLOCK)
8	5015	3X10 SHCS
13	5105	3M LOCKNUTS
2	5010	3X8 SHCS (HORIZONTAL FIN CLAMPS)
1	270	TAIL TRANSMISSION ASSY
2	3053	5X10X4 FLANGE BEARING
1	1740	PINION SPACER (BRASS)
12	5094	3X3 SET SCREWS (COLLARS)
2	5095	3X4 SET SCREWS (PINION GEAR)
1	TWIN 109A	BEARING CARRIER
2	3090	.375X.625X1.56 BEARING
1		CONNECTING SHAFT
2	109I	O'RINGS
1	TWIN 109ABI	DELFIN CARRIER
1	1745	PINION GEAR (TAIL TRANSMISSION)
1	6015	TAIL ROTOR BLADES

BAG 10B

1	1171	FLYBAR
1	1677	TAIL BOOM 37"
2	2117	ARROW DRIVE SHAFT
2	1879	TIE WRAPS
1	1682	PUSH ROD CARBON FIBER SET
2	1983	PUSHROD ENDS
2	1956	BALL LINK 2.5
2	5105	3M LOCKNUT
2	5030	3X20M SHCS
1	TWIN 1709	TAILBOOM SUPPORT SET
2	TWIN 1710	TAIL BOOM SUPPORT STRUTS
4	1715	TAILBOOM SUPPORT STRUT ENDS

BAG 11

42	1956	BALL LINKS 2.5
10	1947	PLASTIC SERVO MOUNT TABS
2	1948	WIRE CLIP
2	1985	ELEVATOR LINKAGE 130M
2	1990	ELEVATOR LINKAGE 50M
4	1995	COLLECTIVE LINKAGE 30M
2	2000	COLLECTIVE LINKAGE 50M
2	2005	AILERON LINKAGE 85M
4	2010	SWASH PLATE LINKAGE 40M
2	2020	PITCH LINKAGE 75M
2	2025	FLYBAR LINKAGE SHORT 12M
8	5137	5X2M BALL
8	5207	2X10M PHSMS
16	5120	2M NUT
1	1921	CANOPY – LEXAN
1	2049	ZENOAH G26H ENGINE

BAG LIST GAS 9 16 98
 REVISED 4/28/06

LOWER FRAMES



1. Lower Frames

Part#	Qty	Description
1506	1	Lower Frame (Left)
1507	1	Lower Frame (Right)
1560	2	Skid Bar - Gas
5090	4	M3x8 FHCS

- On a flat surface, assemble lower frame (left and right) to the (2) skid bars. The countersink holes go to the outside and the frames go on the outside of the vertical portions of the skid bars. Use (4) M3x8 FHCS (Flat Head Cap Screws) and removable threadlocker. **Note: Make sure that the completed and tightened assembly sits flat on a flat surface with no rocking, and the frames should stand up square.**

BATTERY TRAY

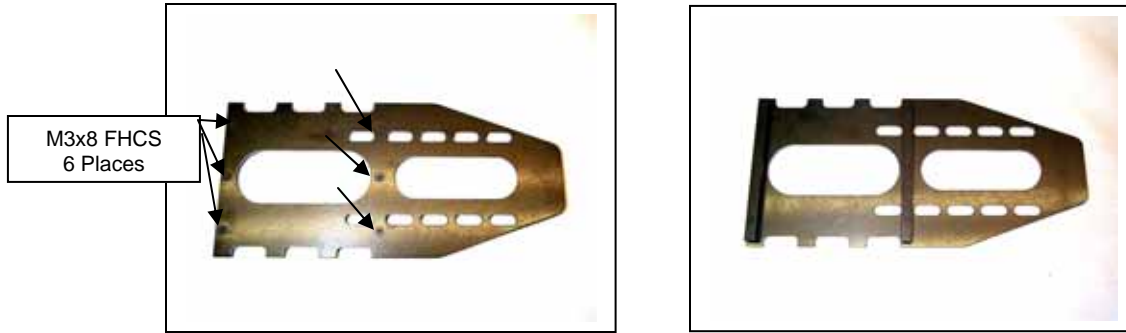

Bottom View Battery Tray, Countersink Holes Up

Battery Tray, Spacers Installed. Top View

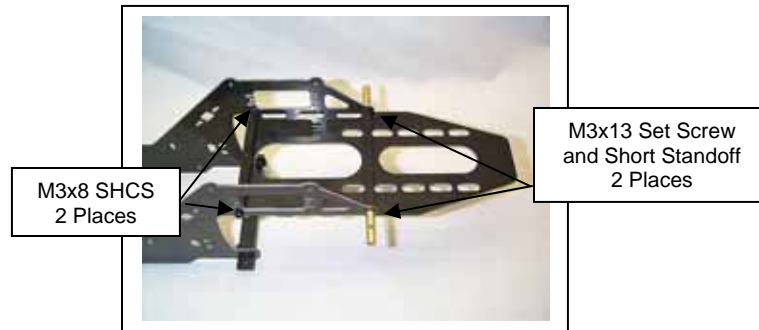

Battery Tray Installed, Top View

2. Battery Tray

Part#	Qty	Description
1520	1	Battery Tray - Gas
1530	2	Battery tray Spacer - Gas
5090	6	M3x8 FHCS
5097	2	M3x13 Setscrew
1933	2	Standoff Short
5010	2	M3x8 SHCS

- Assemble (2) Battery Tray Spacers onto Battery Tray with (6) M3x8 FHCS (Flat Head Socket Screws). The spacers go on the opposite side of the countersink holes. The countersink holes are for the FHCS. Use threadlocker.
- Flip the Battery Tray over and attach to the **lower sideframes** with (2) M3x8 SHCS in the rearmost holes through the sideframe and into the Battery Tray Spacer. Use threadlocker.
- Attach the front of the Battery Tray with (2) M3x13 Setscrews and (2) (Canopy) Standoff Short pieces. Screw the setscrews about half way into the Battery Tray Spacer. Use threadlocker, and let sit for a few minutes to let the threadlocker set up.
- Screw the (2) Short (18mm) Standoffs onto the setscrews and tighten down. Use threadlocker.

LANDING GEAR ASSEMBLY AND MOUNTING



M3x4 Set
Screws
(4 plcs)



3. Landing Gear Assembly and Mounting

Part#	Qty	Description
1574	1	Landing Gear Set (Black or White)
	2	M3x8 self tapping screws
5030	4	M3x16 SHCS
5105	4	M3 Lock Nuts

- Slide a plastic skid strut over one of the metal skids. You may find it necessary to heat the plastic strut in hot water or with a hot air gun in order to expand it, which will enable it to slide over the metal tube.
- Slide the strut forward until it is approximately 2" from the bend.
- Line up the front strut with the holes in the front Skid Bar.
- Now slide the second strut onto the skid until it lines up with the rear holes in the rear Skid Bar on the sideframe assembly.
- Repeat for second skid to form complete Landing Gear Set
- Using the Skid Bars as a guide move the struts as necessary until each is centered beneath the appropriate mounting holes in the Skid Bars in the lengthwise direction. The landing gear should sit flat on the table.
- Center the Skid Bars over the center of both struts and mark the 4 mounting holes to be drilled.
- Remove frame assembly from Landing Gear and drill holes for mounting hardware using a 1/8" drill bit. **Note: There may be other holes predrilled in the struts.**
- Mount Landing Gear to frame assembly using M3x16 SHCS and M3 Lock nuts.
- If the metal skids move around easily, drill a pilot hole (#50) and use (2) 3x8 Self tapping Screws in the bosses at the bottom inside of the rear strut to hold the metal skids from turning.

FAN AND SHROUD ASSEMBLY

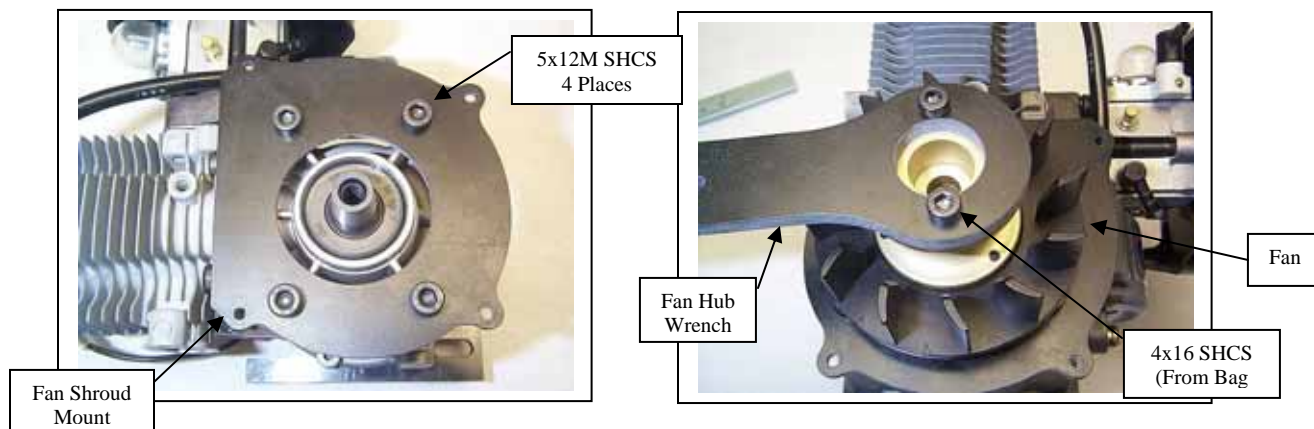

4. Fan and Shroud Assembly

Part#	Qty	Description
1460	1	Fan Shroud Mount
5085	4	5x12M SHCS
1415	1	Fan Assembly - Gas
1455	1	Fan Shroud - Gas
5030	4	3X16M SHCS
5086	1	6X25M SHCS
5130	1	1/4" Lock washer

- Carefully remove carburetor and secondary coil (the coil with the spark plug wire). Note the orientation of the carburetor when removing.
- Place the fan shroud mount on the front of the engine, oriented as shown in the picture. Attach with (4) 5X12 SHCS. Use threadlocker.
- Place a drop of oil on the outer surface of the taper on the crankshaft and spread around with your finger.
- Place the fan assembly on the crankshaft.
- Bolt the fan hub wrench (optional equipment, see your dealer or Bergen R/C Helicopters) to the fan hub with (2) 4x16 SHCS from Bag 6. This is temporary only. Do not use threadlocker.

- Screw the 6x25M SHCS with the ¼” lock washer and **tighten very tight**. Use threadlocker. One hand goes on the fan hub wrench and the other goes onto the Allen wrench and tighten. Dial indicate the fan as shown, tapping on the high side to get the runout to less than .002 “
- Remove the fan hub wrench.
- Trial fit the fan shroud onto the fan shroud mount. The fan shroud should fit against the mount flat without any gaps. Lightly sand with a sanding block if necessary to make sure the shroud does sit flat. Use a hair dryer to warm the shroud to help conform it to the cylinder head and shroud mount.
- Attach the fan shroud to the mount with (4) 3X16 SHCS and 3M locknuts. Orient the heads of the bolts to the top.
- Re-attach the carburetor and the coil. Make sure that the carburetor is oriented in the correct way.



- An option, the BMT #148-GAS, Canfield Balancer can be installed on the fan. Order #148-GAS from your Hobby Shop or Distributor.

STARTER MOUNTING

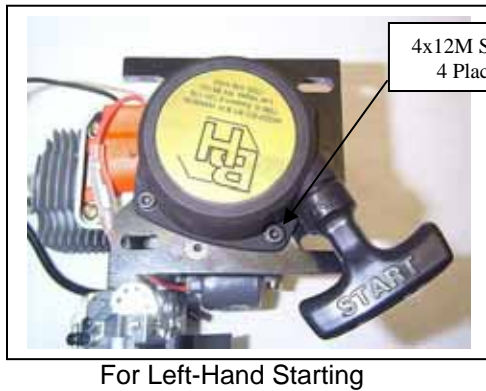
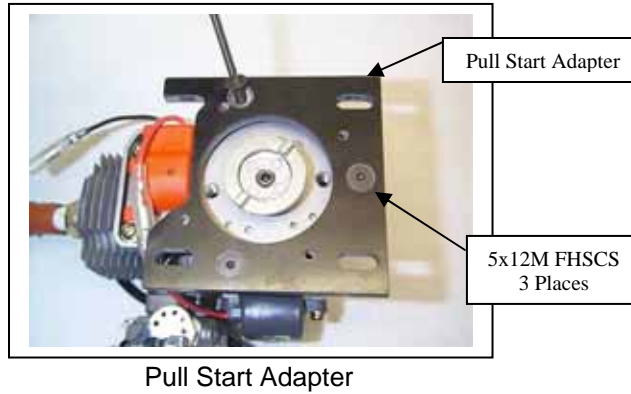

5. Starter Mounting

Part#	Qty	Description
5091	3	5x12M FHSCS
5060	4	4x12M SHCS
2036	1	Pull Start Adapter
N/A	1	Pull Starter (provided with engine)

- Mount the Pull Start Adapter to the back of the engine with (3) 5x12M FHSCS. The countersink is for the flat head on the screw and should be facing up. The large cutout in the adapter is for the primary coil. Use threadlocker.
- Mount the pull starter (provided with engine) to the pull start adapter using (4) 4x12M SHCS. **Special note: DO NOT OVERTIGHTEN THE SCREWS. The screws are threaded into the G-10 adapter. They can be stripped out. Only snug the screws until tight.**
- The starter can be mounted in two ways, one for left-handed people and one for right-handed people. Both ways of mounting are shown.

CLUTCH BUSHING INSTALLATION

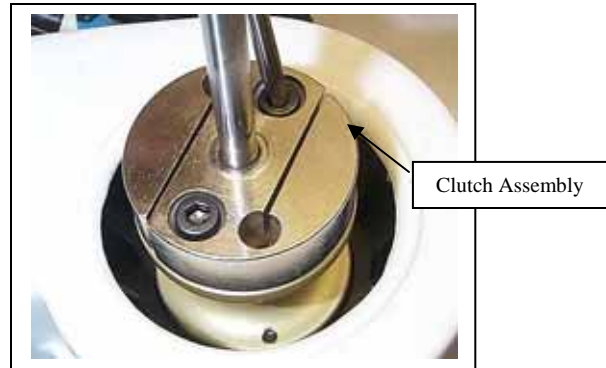
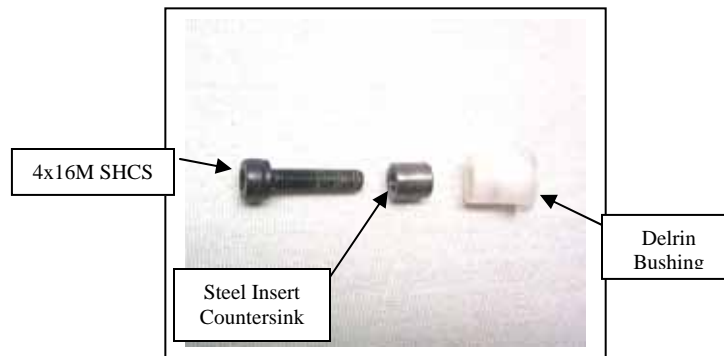

6. Clutch Bushing Installation

Part#	Qty	Description
1300	2	Steel Insert
1295	2	Delrin Bushing
5065	2	4x16M SHCS
1275	1	Clutch Assembly

- Carefully examine the (2) steel inserts. There is one end that has a noticeable countersink on the inside edge. Place the insert onto the 4x16M SHCS with the countersunk end *towards* the head of the SHCS. Slip 4x16M SHCS (with steel insert installed) into Delrin bushing so that screw extends beyond flanged end of Delrin bushing (see illustration above). Repeat the process to complete the 2nd bushing assembly.
- Install both Delrin bushing assemblies onto the fan hub but *do not* fully tighten at this time. Use threadlocker
- Use the clutch as an alignment tool and slip it over the Delrin bushings on fan to ensure proper alignment of the bushings, fully tightening at this time.
- Remove clutch by lifting clutch off of Delrin bushings and reinsert clutch into Clutch Bell Assembly.

ENGINE MOUNTING

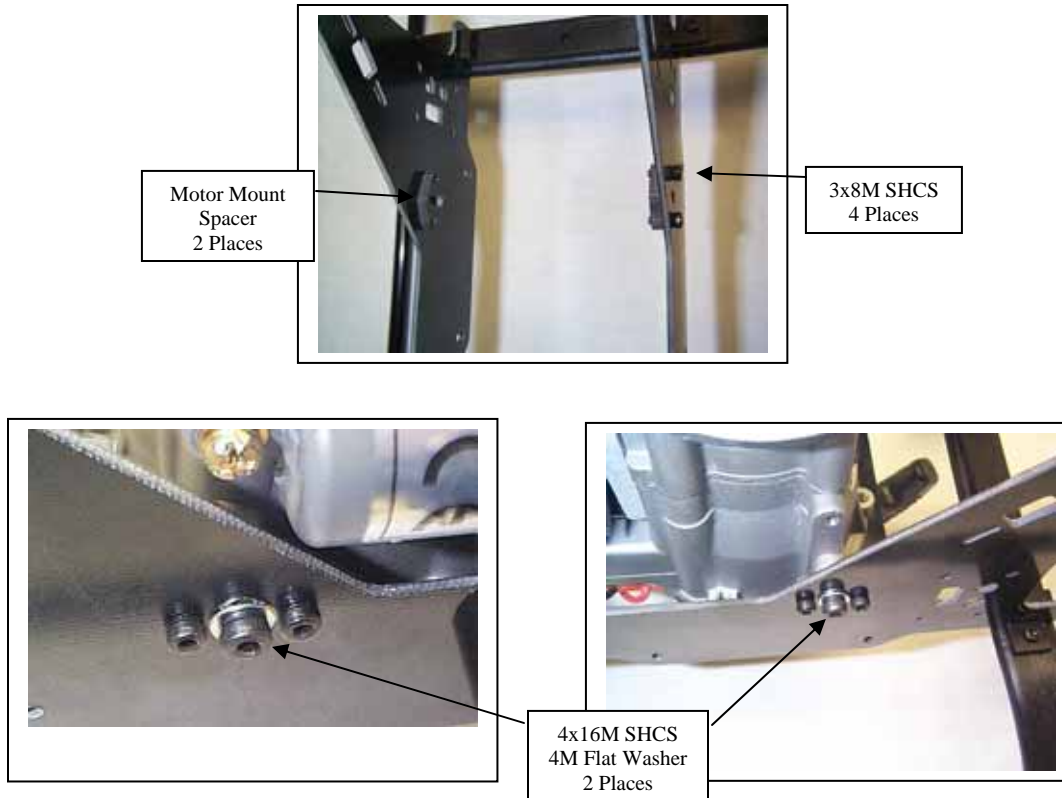

7. Engine Mounting

Part#	Qty	Description
2040	2	Motor Mount Spacer - Gas
5010	4	3x8M SHCS
5065	3	4x16M SHCS
5015	4	3x10M SHCS
5110	2	3M Flat Washer
5109	3	4M Flat Washer
5141	4	3x18M SHCS
5105	4	3M Locknut
231B	8	Special Washer
1470	1	Motor Mount Bracket

- Mount 2 Motor Mount Spacers onto the lower side frames using (4) 3x8M SHCS. Do not use threadlocker.
- Mount the engine crankcase to the lower side frames. The wide engine crankcase threaded mounting locations fit in between the spacers. Lightly secure with (2) 4x16M SHCS and (2) 4M flat washers. Do not use threadlocker at this time. This will be adjusted later.

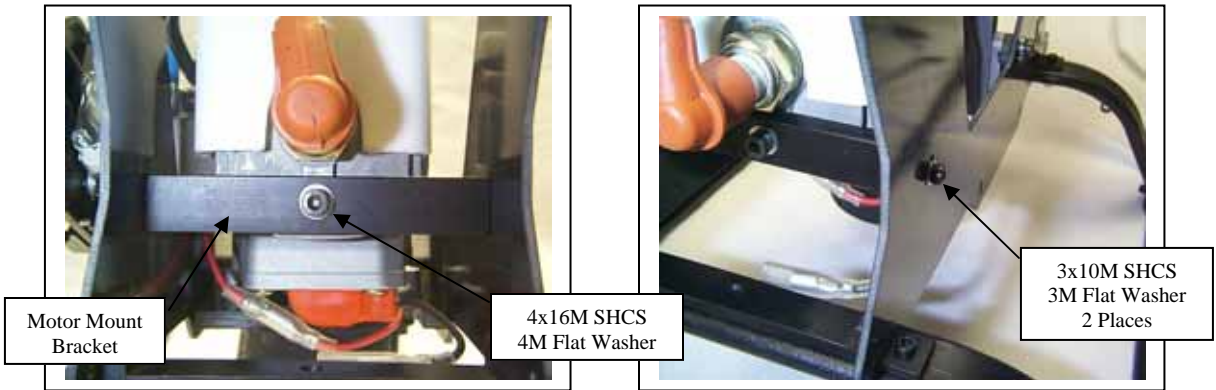

- Attach the Motor Mount Bracket to the head of the engine with (1) 4x16M SHCS and (1) 4M flat washer. Do not use threadlocker at this time. This will be adjusted later.
- Attach the ends of the motor mount bracket to the lower side frames using (2) 3x10M SHCS and (2) 3M flat washers. Do not use threadlocker at this time. This will be adjusted later.

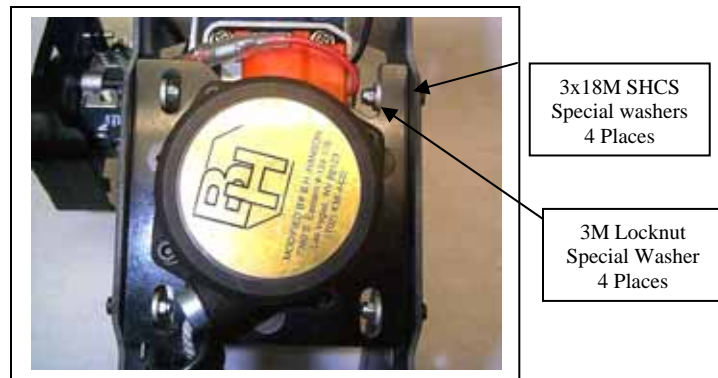

- Attach the pull start adapter to the lower side frames using (4) 3x18M SHCS, (8) Thick special washers, (4) 3M Locknuts in the slotted portion of the adapter plate. Lightly tighten the screws. This will be adjusted later.

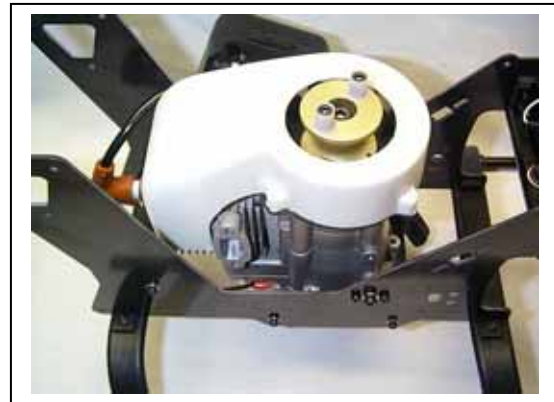

THROTTLE ARM

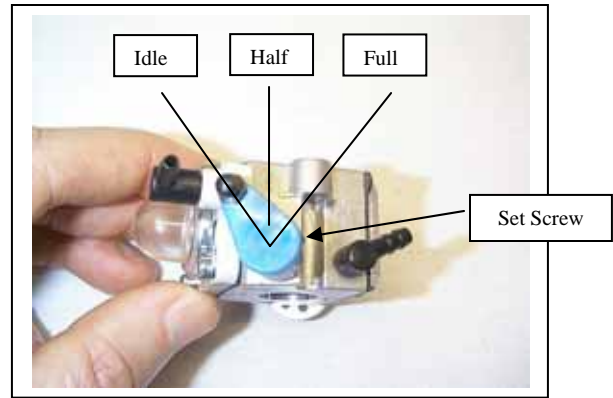
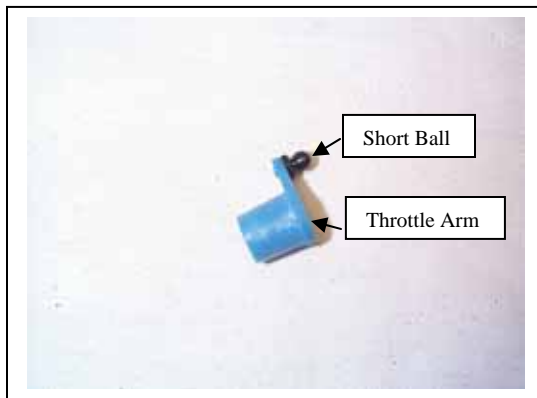

8. Throttle Arm

Part#	Qty	Description
2045	1	Throttle Arm - Gas
5190	1	Short Ball

- Screw a Short Ball into the throttle arm. You're throttle arm will be aluminum.
- Mount the throttle arm onto the carburetor. Adjust the angle of the arm so that it swings the same amount in both directions from parallel to the screw-mounting slot. Tighten the setscrew. Do not use threadlocker at this time. It will be re-adjusted later.

MOUNT LOWER SERVOS

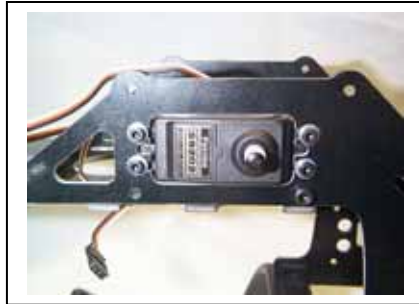
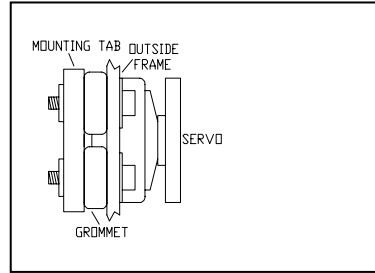

Throttle Servo



Elevator Servo

9. Mount Lower Servos

Part#	Qty	Description
1947	4	Plastic Servo Mount Tabs

- Prepare the servo with the hardware provided with the radio system: install the rubber grommets on the servo mounting ears, and then install the servo mount tabs into the grommets down from the top of the servo ear. Use the plastic servo mounting tabs as nuts and as replacements for the brass eyelets. Use self-tapping screws provided by the radio system for mounting the servos to the tray, or use M2.5x15 SHCS (*not provided in kit*). Screw the screws into the tabs, going in from the outside of the sideframe and screwing into the tab.
- Make sure that servos are mounted with the servo ears on the inside of the side frames.**
- When tightening the screws, be sure to get the servo tight enough that it can't move, but do not squeeze the rubber grommet so much that the isolating properties of the grommet are lost. The servo should be able to rock from side to side slightly when tightened. Paying attention to this important note will increase the lifetime of the servos.*
- Mount the throttle servo to the left lower sideframe with the output shaft towards the rear of the machine. The servo mounting ears (flanges) go on the inside of the frame. Mount the elevator servo to the right lower sideframe with the output shaft towards the rear of the machine. The servo mounting ears (flanges) go on the inside of the frame.

MOUNT COLLECTIVE BEARINGS

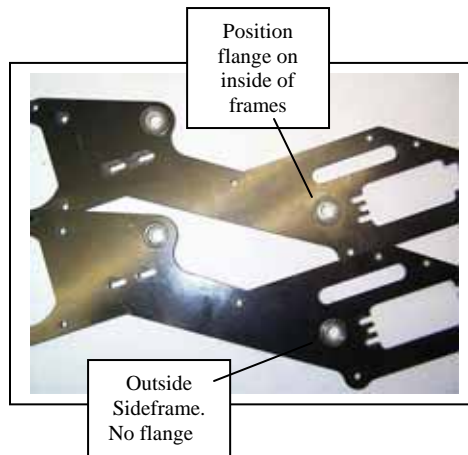

10. Mount Collective Bearings

Part#	Qty	Description
1475	2	Upper Frame
3035	4	6x10x3F Bearing

- Place 2 Collective Shaft Bearings into one side of one of the upper sideframes. Install the flange of the bearing on the same side of the frames. The side with the flange is the inside. If they don't go in easily, use a vise to press them in. **DO NOT HAMMER!** Make sure the flange is seated against the sideframe.
- Secure with a drop of thin CA on the flanges.
- Place 2 Collective Shaft Bearing into the second upper sideframe, **on the opposite side of the upper sideframe**. The flanges should be facing on the opposite side of the second sideframe. The flange side is the inside of the second sideframe.
- Secure with a drop of thin CA on the flanges.

LEFT UPPER FRAME ASSEMBLY



11. Left Upper Frame Assembly

Part#	Qty	Description
5175	5	29M Frame Spacer
5055	5	M3x40 SHCS
5010	1	M3x8 SHCS
5170	5	26M Frame Spacer

- Attach (5) 29M Frame Spacers to the left lower frame with (5) M3x40 SHCS. The Spacers are not threaded, so they will just sit on the screws
- Place the upper left sideframe on the (5) protruding screws and thread on (5) 26M Frame Spacers. Use threadlocker.

MAIN GEAR ASSEMBLY

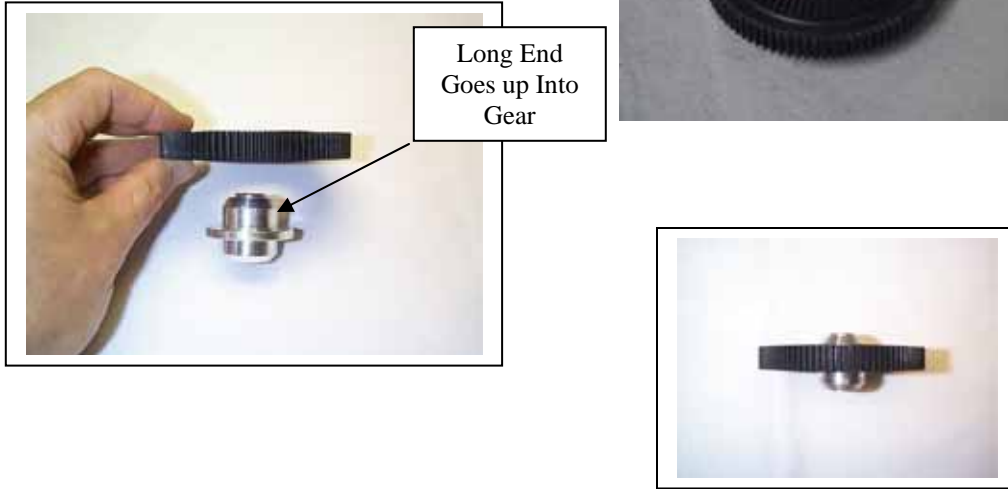

12. Main Gear Assembly

Part#	Qty	Description
1270	1	Main Gear
1265	1	Auto Hub Assembly
5308	4	M3x8 Special Low Head Cap Screw

- Break the sharp edge of bore in main gear before installing on auto hub.
- Position the auto hub assembly so that the longer end is facing up into the main gear. Your main gear is one sided. The top is the side with the inner ring of gears.
- Push through the main gear and align the holes on the gear with the holes on the auto hub assembly.
- Screw the (4) M3x8 special low head cap screws through the main gear into the auto hub assembly. The head portion of the screw is thinner than normal. Use threadlocker.
- Special note: Tighten the 4 screws evenly and snug, but not extremely tight. Overtightening the screws will distort the gear.*

ELEVATOR YOKE ASSEMBLY



13. Elevator Yoke Assembly

Part#	Qty	Description
Bmt280	1	Elevator Control Yoke
5110	2	M3 Washer
5001	2	M3x4 SHCS
1600	1	Elevator Control Shaft Long
1605	1	Elevator Control Shaft Short

- Press (1) elevator control shaft – short into the elevator control yoke. The flattened end of the control shaft fits into the special oblong shape hole in the center of the control yoke.
- Fasten the shaft into the yoke with (1) M3x4 SHCS and (1) M3 washer. *IMPORTANT! Use permanent threadlocker here and tighten very tight!*
- Press (1) elevator control shaft – long into the elevator control yoke on the opposite side. Both ends are slotted on the control shaft. One end will fit into the special oblong hole on the other side of the elevator control yoke.
- Fasten the shaft into the yoke with (1) M3x4 SHCS and (1) M3 washer. *IMPORTANT! Use permanent threadlocker here and tighten very tight!*

TAIL TRANSMISSION ASSEMBLY

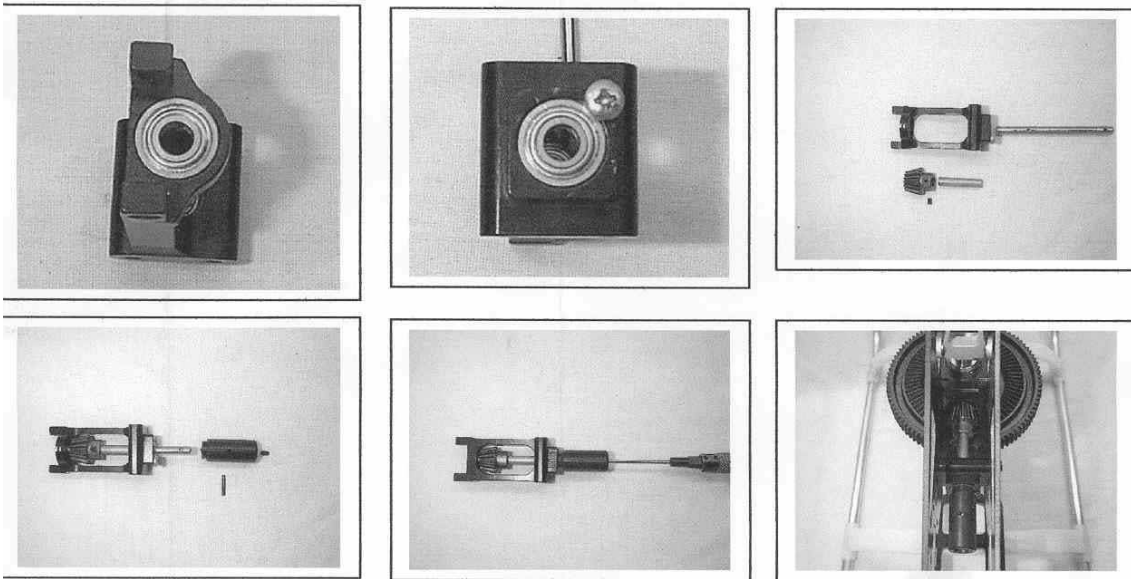

14. Tail Transmission Assembly

Part#	Qty	Description
270B	1	Transmission Cradle
270C	1	Brass Spacer
5095	2	M3x4 Set Screw
9005	1	Tail Transmission Shaft
1745	1	Pinion Gear
9010	1	Delrin Coupler
1210	1	Coupler Pin
5015	4	M3x10 SHCS
5110	4	M3 Washer

- Install (2) M5x13x4 Bearings in the recesses of the tail transmission cradle. Insert (1) M3x5 Phillips head pan screw into the hole next to the front bearing in the cradle. Use thread locker.
- Position the brass spacer and the pinion gear inside the cradle, with the gear facing forward.
- View the tail transmission shaft. Notice that there is a hole on one end and a dimple in the other end. The dimpled end is for the pinion gear and goes forward. The thru hole goes to the rear. Push the shaft through the rear bearing, into the brass spacer and into the pinion gear.
- Align the dimple in the shaft with one of the hole in the gear. Lock the transmission gear onto the shaft with (1) M3x4 setscrew making sure that the setscrew goes into the dimple on the shaft. Use thread locker.
- Push the Delrin Coupler onto the rear of the shaft. The narrow end goes forward. Align the hole in the shaft with the hole in the Delrin Coupler.
- Push the small pin through the hole in the Delrin Coupler, the shaft and into the hole on the other side of the coupler. Center the pin.
- From the rear of the coupler, screw (1) M3x4 setscrew into the threaded end of the shaft to lock the pin into place. Use thread locker.

CLUTCH INSTALLATION



15. Clutch Installation

Part#	Qty	Description
5015	2	M3x10 SHCS
5110	2	M3 Washers

- Set the clutch assembly onto the 2 Delrin bushings on the fan.
- Attach the start shaft bearing assembly to the left upper sideframe with (2) M3x10 SHCS and (2) M3 Washers. Do not tighten down at this time, and no threadlocker at this time.
- Install 6mm collar onto clutch output shaft and secure with set screws and loctite.

MAIN SHAFT ASSEMBLY

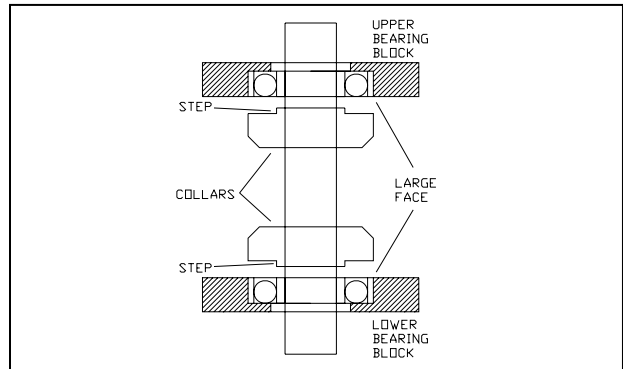

16. Main Shaft Assembly

Part#	Qty	Description
1233	1	Main Shaft Assembly
1245	2	Split Main Shaft Collar Assembly
1250	2	Main Shaft Bearing Block Assembly

- Remove the shaft collar from the main shaft, and re-attach with threadlocker on the retaining screw. Make sure that the step on the collar is facing up. Note: The retaining screw is an American 4-40 screw.
- Slip the main shaft up through the auto hub assembly. The side of the gear with teeth on it is the top.
- Slip (1) Main Shaft Bearing Block Assembly onto the main shaft. Use the bearing block with the 2 corners cut out. The large face of the bearing should face up, away from the gear.
- Slip (1) Split Main Shaft Collar Assembly onto the main shaft. The stepped side of the collar should face down, towards the large face of the bearing.
- Slip the elevator yoke assembly onto the main shaft. It will just hang loose for now. Make sure the long axle is on the right side when installing this assembly into the frames.
- Slip (1) Split Main Shaft Collar Assembly onto the main shaft. The stepped side of the collar should face up, away from the elevator yoke.
- Slip (1) Main Shaft Bearing Block Assembly onto the main shaft. The large face of the bearing should face down, toward the split collar.

MAIN SHAFT AND MAIN GEAR INSTALLATION



17. Main Shaft and Main Gear Installation

Part#	Qty	Description
5050	4	M3x35 SHCS

- Install main shaft assembly by attaching with (4) M3x35 SHCS. The screws go through the holes in the sideframe and then through the holes in the main bearing assemblies.
- **Make sure that the long elevator control shaft on the elevator yoke is facing out the right side of the machine. It cannot be changed later without a lot of disassembly.**

TAIL TRANSMISSION INSTALLATION



18. Tail Transmission Installation

Part#	Qty	Description
5015	2	M3x10 SHCS
5110	2	M3 Washer

- Install tail transmission assembly by screwing (2) M3x10 SHCS through the sideframe and into the tail transmission-bearing block. Do not tighten down at this time, and no threadlocker at this time.
- Note that the transmission dovetails onto the lower main shaft bearing block, and the 3X35 SHCS bolt is installed through both pieces.
- Also note the vertical slot in which the 3X35 bolt resides in. This gives your vertical adjustment for setting the tail drive gear mesh later on.

COLLECTIVE AXLES

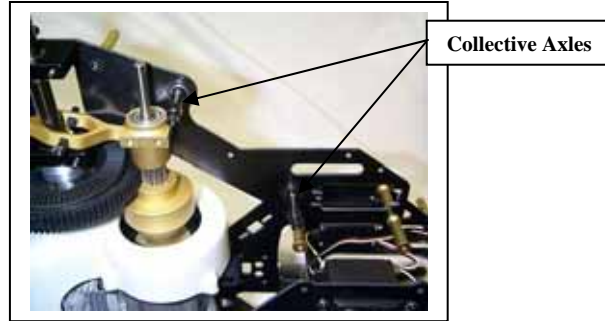

19. Collective Axles

Part#	Qty	Description
1620	2	Collective Axle

- Install (2) collective axles into the collective axle bearings on the inside of the left upper sideframe.

UPPER FRAME ASSEMBLY



20. Upper Frame Assembly

Part#	Qty	Description
5010	1	M3x8 SHCS
1947	4	Plastic Servo Mount Tabs

- Prepare the servo with the hardware provided with the radio system: install the rubber grommets on the servo mounting ears, and then install the servo mount tabs into the grommets down from the top of the servo ear. Use the plastic servo mounting tabs as nuts and as replacements for the brass eyelets. Use self-tapping screws provided by the radio system for mounting the servos to the tray, or use M2.5x15 SHCS (*not provided in kit*). Screw the screws into the tabs, going in from the outside of the sideframe and screwing into the tab.
- When tightening the screws, be sure to get the servo tight enough that it can't move, but do not squeeze the rubber grommet so much that the isolating properties of the grommet are lost. The servo should be able to rock from side to side slightly when tightened. Paying attention to this important note will increase the lifetime of the servos.*
- Mount the collective servo with the output shaft going to the front of the machine. The servo mounting ears (flanges) go on the inside of the frame.

UPPER RIGHT SIDEFAME INSTALLATION

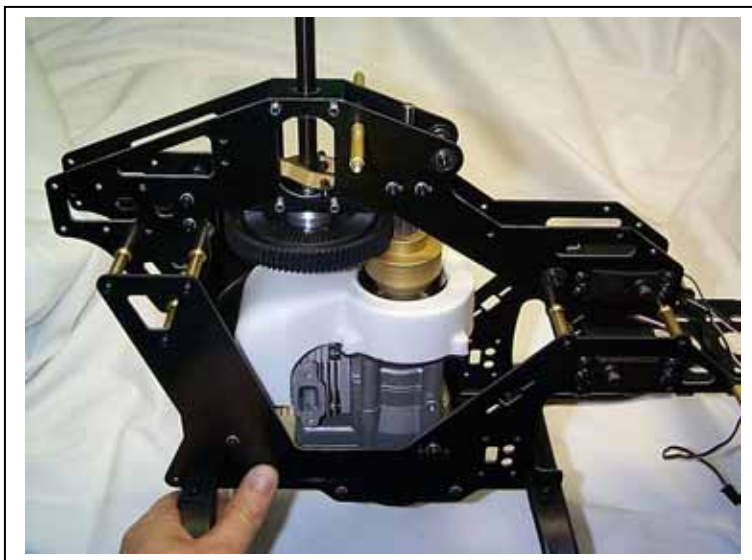

21. Upper Sideframe Installation

Part#	Qty	Description
5055	5	M3x40 SHCS
5175	5	29M Frame Spacer
5105	4	M3 Locknut
5015	2	M3x10 SHCS (for start shaft bearing block)
5110	2	M3 Washer
5015	2	M3x10 SHCS (for tail transmission)
5110	2	M3 Washer

- Test fit the right upper sideframe assembly by holding it up in position and putting in a few 29M frame spacers and M3x40 SHCS. This is a check to see if a modification has to be done to the frame. If there is any sort of interference between the collective servo mounted on the right upper sideframe and the left upper sideframe, then trimming will need to be done. Remove the mounting tabs in the servo hole on the left side of the frame if necessary.



- Fit all (5) 29M frame spacers and (5) M3x40 SHCS into the appropriate spots on the frame assembly. Use threadlocker and tighten down the screws.

- Install the (4) M3 locknuts onto the (4) M3x35 SHCS protruding from the (2) main shaft bearing assemblies. Tighten down thoroughly.
- Pull up on the main shaft to remove all play in the main shaft and auto hub, push down on the lower split collar assembly, and tighten the screw in the collar. Do not use threadlocker on these bolts, but do use a hardened allen driver, not an allen wrench. They're too soft and risk stripping out these bolts.
- Lift up on the upper split collar assembly and tighten the screw in the collar. Do not use threadlocker.
- Attach the right upper sideframe to the start-bearing block with (2) M3x10 SHCS and (2) M3 Washers. Tighten slightly, but allow the block to slip back and forth. Do not apply threadlocker at this time.
- Attach the right upper sideframe to the tail transmission block with (2) M3x10 SHCS and (2) M3 Washers. Tighten slightly, but allow the block to slip up and down. Do not use threadlocker at this time. Move the block up so the tail pinion gear is away from the main gear as much as possible until alignment is done with this gear later on.
- Slightly tighten the (8) engine mounting screws until they contact the sideframes. At this point the engine should still be able to be moved up and down and back and forth with a slight drag.
- Move the entire Engine and Mount Assembly upwards towards the top of the sideframes fully seating clutch bushings and clutch into the clutch bell. Drop the Engine Assembly approximately 1/2mm to allow clutch to "float" on the delrin clutch bushings. This is what allows the Bergen clutch to be self-aligning.
- The triple bearing block and engine assembly can move back and forth. Move the whole assembly backwards together until the pinion gear mesh is tight with the main gear. Test the mesh of the main gear with the clutch gear. You want a minimum amount of backlash without any drag in the mesh. You also want to maintain vertical alignment with the whole drive train system.
- Tighten all screws in the triple bearing block. Then tighten all engine mounting bolts. Now remove one bolt at a time, apply threadlocker, and replace. Again, check the mesh of the main gear and clutch pinion gear.
- Now you can set the tail drive mesh by loosening the rear lower main shaft bearing block bolt, and pushing down on the "cage" until you have minimal backlash with minimal drag on the tail drive system. Retighten the main shaft bearing block bolt.

GYRO TRAY AND BATTERY MONITOR

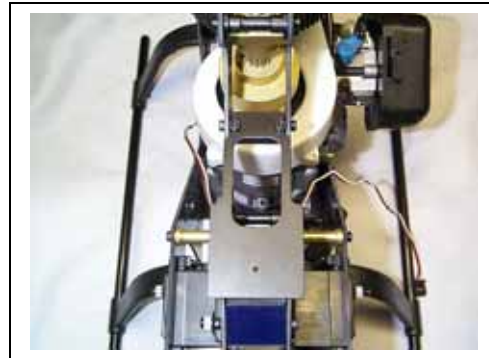
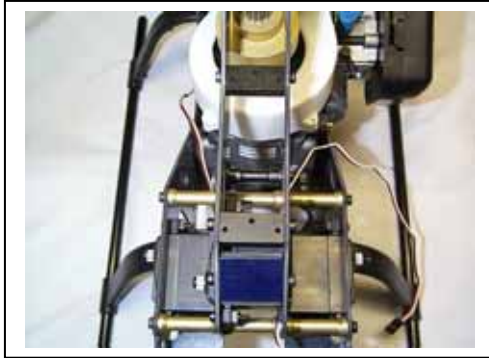

22. Gyro Tray and Battery Monitor

Part#	Qty	Description
1546	2	Gyro Mount Block 3 Hole
5090	1	M3x8 FHSCS
5010	8	M3x8 SHCS
1545	1	Gyro Mount
1550	1	Battery Monitor Mount

- Bolt (2) gyro mount blocks in between the sideframes above the lower collective axle. The single hole faces towards the rear. Use (4) M3x8 SHCS. The gyro mount blocks should be flush with the top of the sideframe. Turn the blocks around and then flip over if they aren't flush.
- Bolt the gyro mount on top of the gyro blocks. The countersink hole in the gyro mount should be facing up. Use (1) M3x8 FHSCS in the front hole, and (2) M3x8 SHCS in the rear (2) holes.
- Bolt the battery monitor mount in front of the gyro tray. The beveled edge faces up and forward. Use (2) M3x8 SHCS.
- Do not use threadlocker on these bolts, but you can use a drop of CA glue instead.

CONTROL ARMS



23. Control Arms

Part#	Qty	Description
1641	2	Aileron Bellcrank
1651	1	Elevator "X" Control Arm
3031	6	5x8x2.5F Bearing
5190	6	Short Balls
5200	2	Long Balls
5030	2	M3x16 SHCS
5035	1	M3x20 SHCS
1645	3	Control Arm Jamnut

- Press (2) 5x8x2.5F bearings into the (2) aileron bellcranks and the elevator control "X" arm. The flanges should be seated flush.
- Screw (2) short balls into the (2) aileron bellcranks, with the balls pointing in the opposite direction of the bearing protrusion on the bellcrank. Use threadlocker.
- Screw (2) long balls onto the medium size arms on the "X" arm (the picture shows medium balls[Ⓢ]), with the balls pointing away from the bearing protrusion on the arm. Use threadlocker.
- Screw (1) short ball onto the long arm on the "X" arm. The ball should be pointing in the same direction as the bearing protrusion. Use threadlocker.
- Screw (1) short ball onto the shortest arm on the "X" arm. The ball should be pointing in the same direction as the bearing protrusion. Use threadlocker.
- Push (1) control arm jamnut into each of the (2) aileron bellcranks. The jamnut should go into the side with the bearing protrusion. Screw (1) M3x16 SHCS into the jamnut from the other side of each aileron bellcrank.
- Push (1) control arm jamnut into the "X" arm. The jamnut should go into the side with the bearing protrusion. Screw (1) M3x20 SHCS into the jamnut from the other side of the "X" arm.



Part#	Qty	Description
1630	1	Collective Bellcrank Single
1625	1	Collective Bellcrank Triple
1610	1	Elevator Control Arm
5190	4	Short Balls
5200	2	Long Balls

- Insert (1) short ball into the single collective bellcrank. Use threadlocker.
- Insert (2) short balls into the elevator control arm, both on the same side. Use threadlocker.
- Insert (1) short ball into the triple collective bellcrank, on the arm that the elongated slot points to. Use threadlocker.
- Insert (2) long balls into the same side of the triple collective bellcrank, on the arms that point away from the elongated slot. Use threadlocker.

COLLECTIVE ARMS



24. Collective Arms

Part#	Qty	Description
1616	2	Collective Arm
5190	2	short Balls
3031	2	5x8x2.5F Bearing

- Insert (1) 5x8x2.5F Bearing into each collective arm. Make sure that the bearing is seated and that the flange is flush. The flange is the outside of the arm.
- Insert (1) short ball into the outside of each arm. There are 2 holes in the front. The inner hole gives more collective movement than the outer hole. Use threadlocker.
- Screw (1) aileron bellcrank assembly onto the outside of each collective arm in the hole next to the bearing. Adjust the screw and the jamnut to give proper movement of the bellcrank with no slop. The jamnut gets tightened against the collective arm. Screw in the screw until the bellcrank feels notchy to move. Then back out the screw until it just becomes free. Tighten down the jamnut and re-check. Use threadlocker.

COLLECTIVE ARM INSTALLATION



25. Collective Arm Installation

Part#	Qty	Description
5010	1	M3x8 SHCS
5001	2	M3x4 SHCS
5110	2	M3 Washer

- Press (1) collective arm assembly onto each side of the upper collective axle. The flat ends of the collective axle fit into the elongated holes on the collective arms. The flanged bearings on the ends of the collective arms should slide over the elevator control shafts on the elevator yoke.
- On the left-hand side, screw (1) M3x8 SHCS and (1) M3 washer into the collective axle, capturing the collective arm in its place. Use threadlocker.
- On the right-hand side, screw the "X" arm assembly into the collective axle. Adjust the screw and the jamnut to obtain free movement. The jamnut gets tightened against the collective arm. Tighten the screw and jamnut until the "X" arm movement becomes notchy or bumpy. Loosen the screw until the freeplay just reappears without any slop. Tighten the jamnut once again and re-check. Use threadlocker here.
- On the left-hand side, screw (1) M3x4 SHCS into the left elevator control shaft on the elevator yoke. This will keep the control shaft from slipping off of the collective arm. Use threadlocker.
- On the right-hand side, press the elevator control arm assembly onto the long slotted elevator control shaft on the yoke. This shaft should be through the bearing on the collective arm. The flat end of the control shaft fits into the elongated hole in the elevator control arm. The longer end of the arm points up.
- Screw (1) M3x4 SHCS and (1) M3 washer into the end of the long control shaft, capturing the elevator control arm in its place. Use threadlocker.
- Check that the whole collective assembly moves up and down freely with no movement side to side.

COLLECTIVE BELLCRANK INSTALLATION



26. Collective Bellcrank Installation

Part#	Qty	Description
5010	2	M3x8 SHCS
5105	2	M3 Washer

- On the left-hand side, press the single collective bellcrank onto the lower collective axle. The flat end of the axle fits into the elongated hole in the single bellcrank.
- Screw (1) M3x8 SHCS and (1) M3 washer into the end of the axle, capturing the single collective bellcrank onto the axle. Use threadlocker.
- On the right-hand side, press the triple collective bellcrank on the lower collective axle. The flat end of the axle fits into the elongated hole in the triple bellcrank. Use threadlocker. *Note: the arm of the triple collective bellcrank with the short ball should be pointing to the engine when the single collective bellcrank is pointing to the engine.*

SERVO ARMS AND LINKAGES

Now it is time to start connecting the various systems on the helicopter to the radio components. There are a few basic items to be aware of when connecting push rods to servo arms. When mounting balls to the various servo arms and levers, or bell cranks, please use a thread-locking component to ensure that all of these critical items stay solidly attached. Lock-tite "242" is a good choice for metal-to-metal connections, and a small drop of Cyanoacrylate glue is a wise choice for metal-to-plastic connections.

Before these connections can be completed, you must determine what length is needed on the servo arm. This determines the amount of control input that will be available when you fly your new creation. This is normally measured as the length from the center of the servo arm to the center of the ball that is mounted to the servo arm. A length should be chosen that gives each linkage the fullest range of movement possible, while the travel volumes on the radio are adjusted to a value of 100%.

There is a general trend to set the travel volumes electronically to the largest value available and adjust the linkage accordingly. This volume is usually 140 to 150 "percent". This lessens the torque requirements of the servo, and is said to be better. We have found that for other reasons, this is not always the best way to adjust your radio. The reason being is that on some radios, if the travel volume is "maxed-out", and the neutral point is shifted...i.e. trimmed while in-flight, the servo will reach maximum movement before the transmitter control reaches it's extreme. In other words, it will seem that the helicopter only responds to the first 80 or 90 percent of the stick movement, and does not respond to any more input. This is one reason that it is not good to set your tail-rotor to maximum on the travel volumes. Once the torque compensation is set, the neutral point of the servo will be changing with the collective input. At one extreme on the collective, you will run out of right rudder as the neutral point of the servo is already shifted in that direction, and at the other extreme, you will run out of left rudder for the same reason. This also creates a problem when two functions are mixed electronically. The same situation will arise with the tail-rotor.

The reason for the offsets on the aileron servo and the elevator servo is to eliminate differential movement on each side of the servo, and therefore eliminate binding of the linkages. Whenever a pushrod is connected to a rotary output, such as that from the servo, the location of attachment must be carefully determined to equalize movement in both directions. If you were to draw an imaginary line from the center of the servo arm to the linkage attachment, and then measure the angle formed by that line and the pushrod, the angle should ALWAYS be 90 degrees, **except** in the case of the collective servo on the **Intrepid Gas EB**. If this is not a 90 degree angle, you will experience differential movement...i.e. more movement in one direction than the other. If this linkage is of the "push-pull" variety, you will also bind the linkage, causing premature wear on the servo. Every linkage on the Intrepid cyclic/collective system is push-pull, and although this is preferable over a single pushrod arrangement, it takes a little more care to properly adjust. Once the balls are attached to these servo arms, we must connect pushrods from the servo arms to the various levers, and bell cranks. Just as it is important to make all pushrod attachments at 90 degrees to the servo arm, it is equally important to make sure that all push-pull linkages are of the same length. Whenever you are fitting two pushrods onto a push-pull configuration, the pushrods MUST be of exactly equal length. If this is not so, the linkage will bind, and therefore prematurely wear your servos.

When attaching pushrods, we want to achieve a smooth, free movement with a minimum of freeplay. Due to the material that ball links are made of, you will find that some links are tighter than others. This happens as a result of the hot plastic being removed from the mold and

shrinking in certain areas. If a link is abnormally tight, there is a quick way of freeing up its motion. While the link is snapped onto the ball, you can “pinch” the link on either side with the use of pliers. This will usually loosen the link to an acceptable level of movement.

All of the bell cranks and levers on the Intrepid are supported by bearings, and to achieve the greatest benefit of the bearings, they must be adjusted for a minimum of freeplay, and a maximum of freedom of movement. This is very easy to do, but requires a little patience, and a small investment in time. The items that must be attended to are the aileron bell cranks, the “X” Arm, the washout levers, and the bell-hiller mixers on each blade holder. All of these pivot on 3mm bolts. Each of the bolts should be snugged up until a very slight binding occurs on the bearings. The lever will begin to feel bumpy or notchy when it is rotated. Then the bolts should be loosened only enough to achieve free movement. Of course Loctite should be used before assembly of all of these items. The pivot bolts that mount the washout arms are also secured with a 3mm grub screw that is inserted from the opposite side of the mixing base. This acts much like a “jam” nut. It takes some fiddling with these bolts to obtain the right adjustment. Each time the grub screw is tightened, it will tend to push the pivot bolt slightly outwards, and increase the freeplay. This bolt must therefore be tightened until the slight friction occurs, then the grub screw is tightened, and you check for freedom of movement. If the friction is still present, loosen the pivot bolt 1/64 of a turn or so, and re-tighten the grub screw.

AILERON SERVO

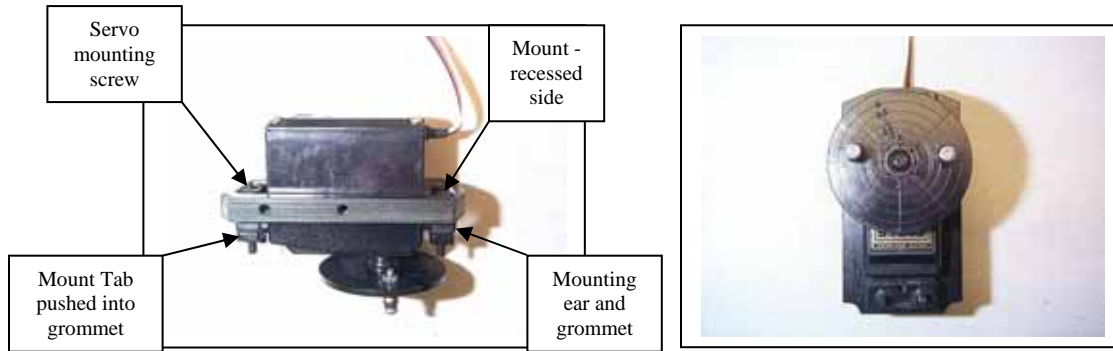

27. Aileron Servo

Part#	Qty	Description
1540	1	Aileron Servo Mount
1947	2	Plastic Servo Mount Tabs
5120	4	M2 Nut
52207	2	M2x10 Philips Screw
5137	2	M2x5 Ball

- The aileron servo mounts to the servo mount with the mounting ears of the servo sitting on the flat side of the mount, away from the recessed side. The plastic mounting tabs fit into the recesses on the aileron servo mount. The output side of the servo points towards the beveled edges of the aileron servo mounts.
- Prepare the servo with the hardware provided with the radio system: install the rubber grommets on the servo mounting ears, and then install the servo mount tabs into the grommets down from the top of the servo ear. Use the plastic servo mounting tabs as nuts and as replacements for the brass eyelets. Use self-tapping screws provided by the radio system for mounting the servos to the tray, or use M2.5x15 SHCS (*not provided in kit*). Screw the screws into the tabs, coming up from underneath the tray as it is screwed in.
- When tightening the screws, be sure to get the servo tight enough that it can't move, but do not squeeze the rubber grommet so much that the isolating properties of the grommet are lost. The servo should be able to rock from side to side slightly when tightened. Paying attention to this important note will increase the lifetime of the servos.*
- Prepare the Servo output arm (disc) by drilling as shown in the diagram. These are the correct dimensions for a Futaba servo. Use a 2mm drill.

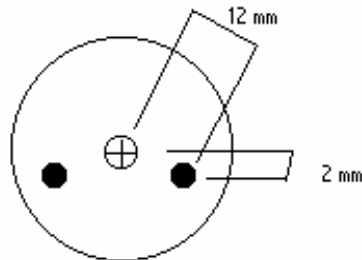

- Put the ball on the Philips screw, followed by a M2 nut. Use threadlocker, but sparingly.
- Screw into the servo arm in one of the holes drilled so the ball will be facing up when installed on the servo.
- Put another M2 nut on the backside of the disc on the screw. Use threadlocker, sparingly.
- Repeat previous steps with the other screw and ball.
- Install on the servo so that when the servo is centered, the balls will be aligned perpendicular to the servo body.
- If using JR radio gear, the JR small white servo wheel already has holes that can be used.

AILERON SERVO INSTALLATION

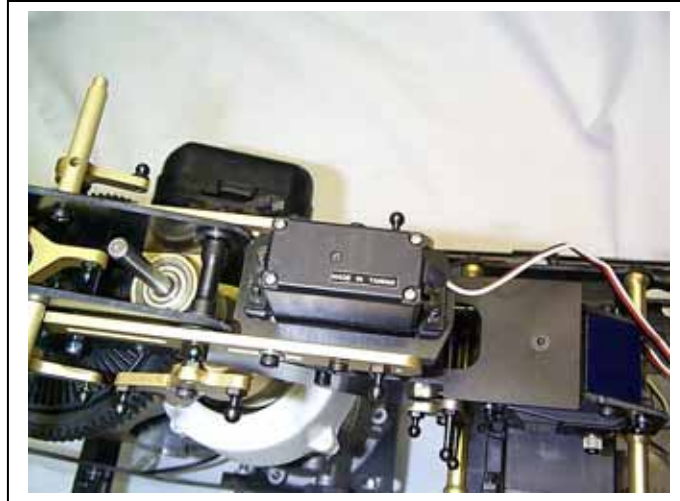

28. Aileron Servo Installation

Part#	Qty	Description
5010	4	M3x8 SHCS
5110	2	M3 Washer

- Install the aileron servo assembly in between the collective arms. The angled edge of the servo mount faces to the front, and the servo bottom faces up. Use (2) M3x8 SHCS in the middle hole on each side of the servo mount. Tighten sufficiently, but do not overtighten and strip the threads.
- In the rear holes, use (2) M3x8 SHCS and (2) M3 washers. These (2) screws go in the slot on the collective arms, and the rear-most holes in the servo mount. Tighten sufficiently, but do not overtighten and strip the threads.
- A drop of CA on these screws will help keep them secure.

AILERON PUSHRODS

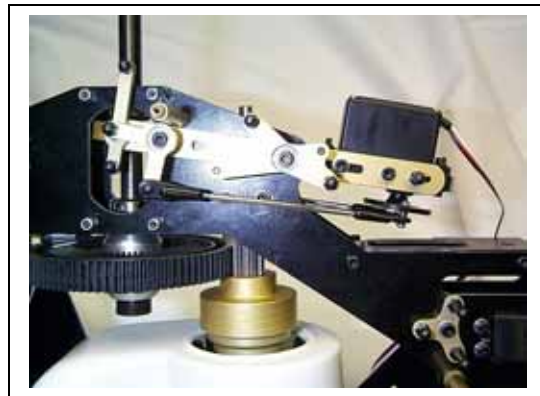

29. Aileron Pushrods

Part#	Qty	Description
1956	4	Ball Link 2.5
2005	2	Aileron Linkage 85mm

- Thread (2) ball links onto the pitch linkage. Thread them on equally.
- The final length of the link assembly will be 106mm center of hole to center of hole. There should be a 90-degree turn in one of the links.*
- Make (1) more linkage assembly, *and make sure that they are the same length. This is very important, as incorrect linkage lengths will lead to binding.*
- Snap one end of one link assembly onto the right side aileron servo ball. The other end will snap onto the right side aileron bellcrank arm that's facing down. The remaining arm of that bellcrank should be facing to the rear. Repeat the process on the other side of the machine with the other link assembly.
- If the links are tight on the balls, use a ball link-sizing tool to adjust the hole size in the links.

COLLECTIVE SERVO WHEEL

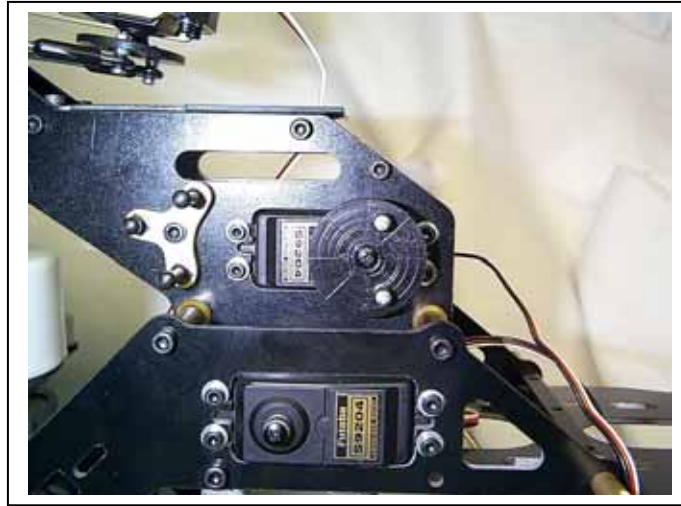

30. Collective Servo Wheel

Part#	Qty	Description
5137	2	M2x5 Ball
5207	2	M2x10 Philips Screw
5120	2	M2 Nut

- Prepare the Servo output arm (disc) by drilling as shown in the diagram. These are the correct dimensions for a Futaba servo. Use a 2mm drill. Collective Servo disk ball locations should be identical to primary bell crank ball locations.

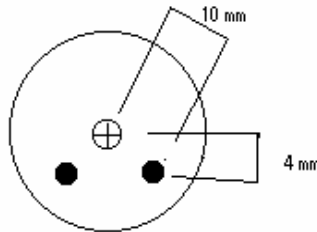

- Put the ball on the Philips screw, followed by a M2 nut. Use threadlocker, but sparingly.
- Screw into the servo arm in one of the holes drilled so the ball will be facing up when installed on the servo.
- Put another M2 nut on the backside of the disc on the screw. Use threadlocker, sparingly.
- Repeat previous steps with the other screw and ball.
- Install on the servo so that when the servo is centered, the balls will be aligned vertically.
- If using JR radio gear, the small white servo wheel can be used with the existing holes.

PRIMARY COLLECTIVE PUSHRODS

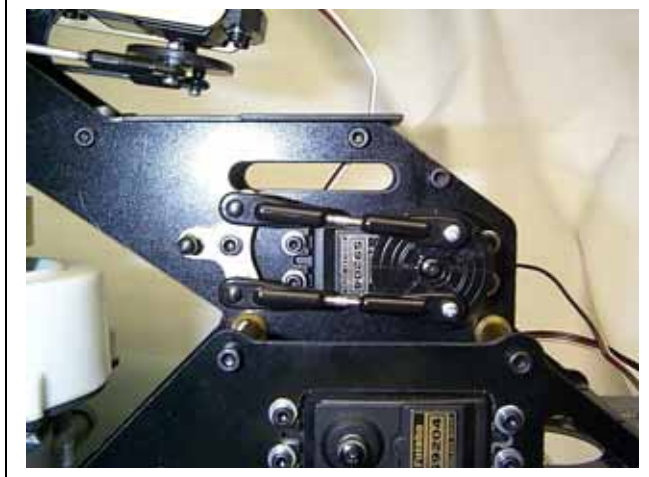

31. Primary Collective Pushrods

Part#	Qty	Description
1956	4	Ball Link 2.5
1995	2	Collective Linkage 30mm

- Thread (2) ball links onto the pitch linkage. Thread them on equally.
- The final length of the link assembly will be 51mm from center of hole to center of hole.*
- Make (1) more linkage assembly, *and make sure that they are the same length. This is very important, as incorrect linkage lengths will lead to binding.*
- Snap one end of one link assembly onto the top collective servo disc ball. The other end will snap onto the top (long ball) of the triple collective arm. The short ball of the triple collective arm should be facing to the rear of the machine.
- Repeat the process with the remaining link assembly.
- If the links are tight on the balls, use a ball link-sizing tool to adjust the hole size in the links.

SECONDARY COLLECTIVE PUSHRODS

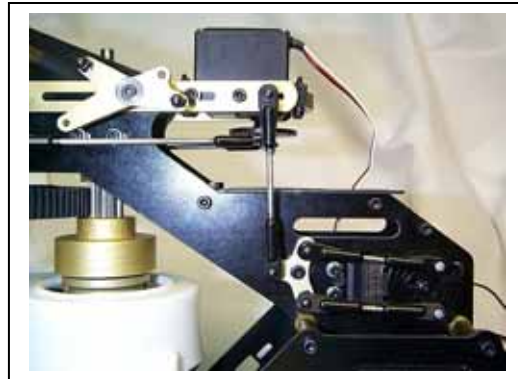

32. Secondary Collective Pushrods

Part#	Qty	Description
1956	4	Ball Link 2.5
2000	2	Collective Linkage 50mm

- Thread (2) ball links onto the pitch linkage. Thread them on equally.
- The final length of the link assembly will be 70mm from center of hole to center of hole.*
- Make (1) more linkage assembly, *and make sure that they are the same length. This is very important, as incorrect linkage lengths will lead to binding.*
- Snap one end of one link assembly onto the single collective bellcrank (right side). The other end will snap onto the right side collective arm.
- Snap one end of the remaining link assembly onto the triple collective bellcrank (left side), the short ball. The other end of the link snaps onto the left side collective arm.
- If the links are tight on the balls, use a ball link-sizing tool to adjust the hole size in the links.

ELEVATOR PUSHRODS

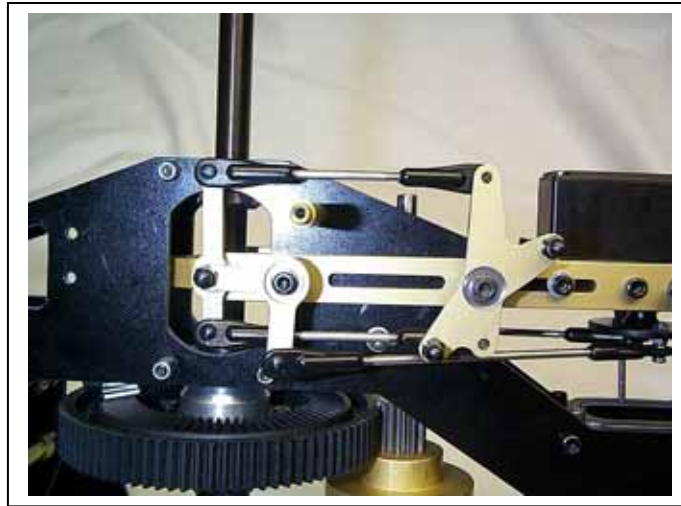

33. Elevator Pushrods

Part#	Qty	Description
1956	4	Ball Link 2.5
1990	2	Elevator Linkage 50mm

- Thread (2) ball links onto the pitch linkage. Thread them on equally.
- The final length of the link assembly will be 70mm from center of hole to center of hole.*
- Make (1) more linkage assembly, *and make sure that they are the same length. This is very important, as incorrect linkage lengths will lead to binding.*
- Snap one end of one link assembly onto the upper ball on the elevator "X" arm (the ball facing inside). The other end will snap onto the upper elevator control arm ball.
- Snap one end of the remaining link assembly onto the lower ball on the "X" arm (the ball facing on the inside). The other end of the link snaps onto the lower elevator control arm ball.
- If the links are tight on the balls, use a ball link-sizing tool to adjust the hole size in the links.

ELEVATOR SERVO AND PUSHRODS

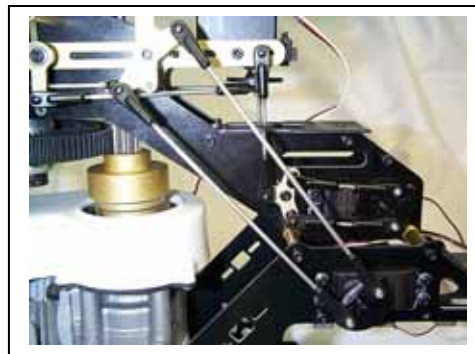
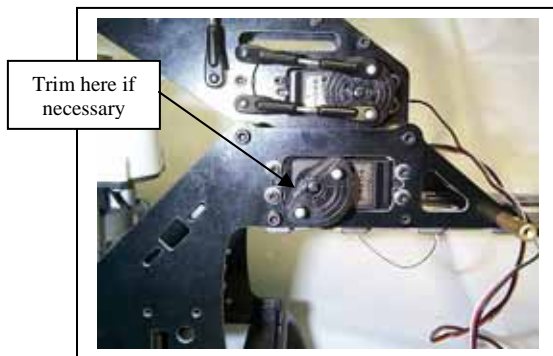

34. Elevator Servo and Pushrods

Part#	Qty	Description
5137	2	M5x2 Ball
5207	2	M2x10 Philips Screw
5120	2	M2 Nut
1956	4	Ball Link 2.5
1985	2	Elevator Linkage 130mm

- Power the servo using the radio system. Set the elevator ATV settings at 85% on each side of center stick. With the stick centered, determine which position of the disk will line up with the longest arms on the X-arm. Use 2 small rulers to determine this. Position the X-arm ruler to line up with the balls on the longest arms. Position the servo disk ruler on one of the lines if the servo disk has lines on it. Use them if possible; it will make marking and drilling easier. Make the rulers, line and X-arm all parallel to each other. If there are no lines, draw a line on the servo disk that is parallel to the X-arm.
- Prepare the Servo output arm (disc) by drilling as shown in the diagram. These are the correct dimensions for a Futaba servo. Use the line on the disk and measure 10mm out from the center on the line and 2mm offset from the line (offset away from the X-arm). Use a 2mm drill to drill the holes. The arm may need trimming to clear the ball links. See picture.

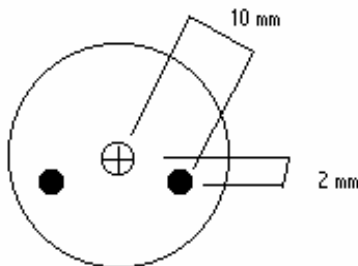

- Put the ball on the Philips screw, followed by a M2 nut. Use threadlocker, but sparingly.
- Screw into the servo arm in one of the holes drilled so the ball will be facing up when installed on the servo.
- Put another M2 nut on the backside of the disc on the screw. Use threadlocker, sparingly.
- Repeat previous steps with the other screw and ball.

- Thread (2) ball links onto the pitch linkage. Thread them on equally.
- The final length of the link assembly will be 149mm from center of hole to center of hole.*
- Make (1) more linkage assembly. Make it the same size as the first one.
- Snap one end of first link assembly onto the outer right-hand short ball on the elevator "X" arm. The other end will snap onto the right-hand ball on the servo disc.
- Snap one end of the second link assembly onto the outer left-hand short ball on the "X" arm. The other end of the link snaps onto the left-hand ball on the servo disc.
- If using JR radio gear, the small white servo wheel can be used with the existing holes.
- If the links are tight on the balls, use a ball link-sizing tool to adjust the hole size in the links.

THROTTLE LINKAGE

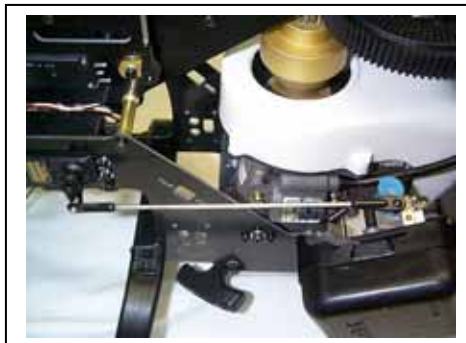

35. Throttle Linkage

Part#	Qty	Description
5137	1	M2x5 Ball
5207	1	M2x10 PHSMS
5120	2	M2 Nut
1980	1	Throttle Linkage 140mm
1956	2	Ball Link 2.5

- Determine which arm of the servo will point straight down at half throttle. Power the servo with the radio system and set the throttle ATV settings at 100% for each side of half stick.
- Position the throttle at the half stick position. Remove and place the arm at different positions of the spline on the output shaft of the servo until the proper arm points straight down. This will be the arm to attach the ball to.
- Prepare the Servo output arm by drilling as shown in the diagram. Use a 2mm drill.

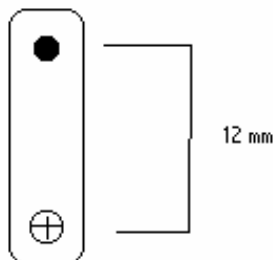

- Put the ball on the Phillips screw, followed by a M2 nut. Use threadlocker, but sparingly.
- Screw into the servo arm in one of the holes drilled so the ball will be facing up when installed on the servo.
- Put another M2 nut on the backside of the arm on the screw. Use threadlocker, sparingly.
- Thread (2) ball links onto the pitch linkage. Thread them on equally.

- The final length of the link assembly will be 160mm from center of hole to center of hole.*
- Snap one end of the link assembly to the servo arm ball. Snap the other end to the throttle extension ball.
- For alignment, the servo arm should be centered and vertical for a half-throttle setting. The Throttle arm on the carb should also be vertical for a half-throttle opening of the carburetor.

SWASHPLATE



36. Swash plate

Part#	Qty	Description
1215	1	Swashplate Assembly
5195	4	Medium Ball
5190	4	Short Ball

- Attach (4) short balls to the threaded holes in the outer swashplate. Use threadlocker.
- Attach (4) medium balls to the inner swashplate. Use threadlocker.
- Install completed swashplate assembly on main shaft.

LOWER SWASHPLATE LINKAGES

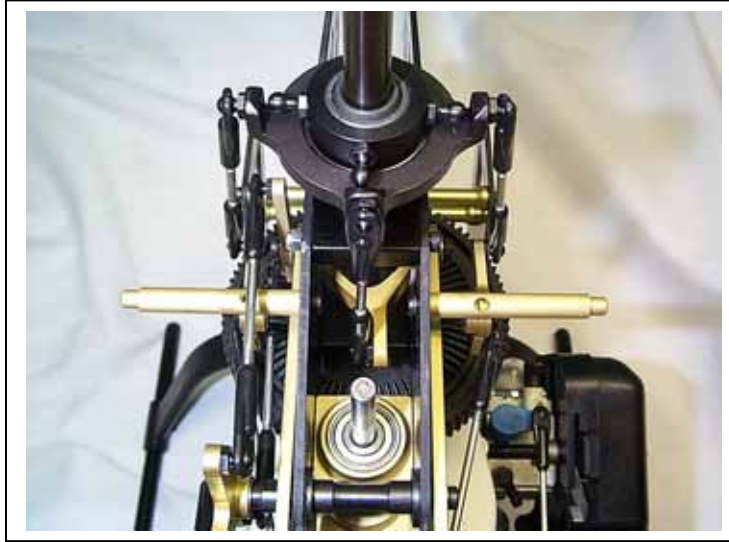

37. Lower Swash plate Linkages

Part#	Qty	Description
1956	4	Ball Link 2.5
2010	2	Swashplate linkage 40mm

- Thread (2) ball links onto the pitch linkage. Thread them on equally.
- The final length of the link assembly will be 58mm from center of hole to center of hole.*
- Make (1) more linkage assembly, *and make sure that they are both the same length. This is very important, as incorrect linkage lengths will lead to binding.*
- Snap (1) link assembly from the left side aileron bellcrank to one of the lower (nonrotating) swashplate balls.
- Repeat on the right side bellcrank to swashplate.
- Snap the links from the elevator control yoke on the fore and aft balls of the swashplate. The length of the "A" arms and links should also be 58mm measuring from the thru pin to the center of the hole in the ball link.
- If the links are tight on the balls, use a ball link-sizing tool to adjust the hole size in the links..

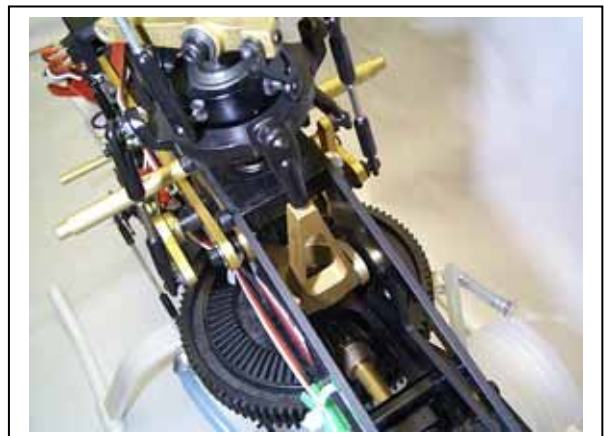
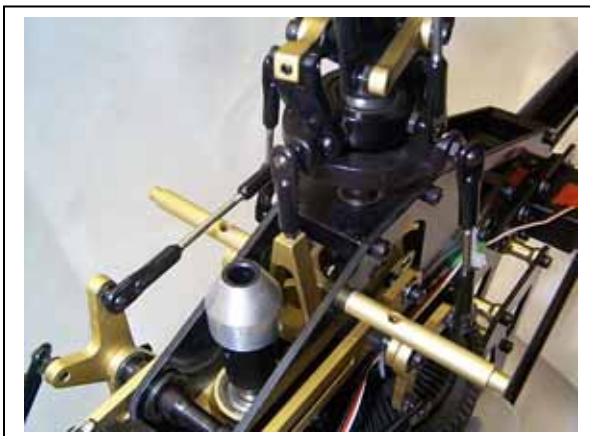

WASHOUT ASSEMBLY



38. Washout Assembly

Part#	Qty	Description
1185	1	Washout Hub Assembly
1201	2	Washout Mixing Arm
3086	4	3x7x3F Bearing
5140	2	M3x16 Special SHCS
5155	2	M3 Brass Washer
5095	4	M3x4 Set Screw
1205	2	Radius Link
2120	2	Radius Link Pin
5190	2	Short Ball

- Screw (1) short ball into each washout-mixing arm. The ball goes on the side away from the bearing protrusion in the arm. The ball side of the arm is the inside of the arm. Use threadlocker.
- Fit (1) radius link to the back end of each washout-mixing arm. Using the "Left Handed" link the bend in the radius link goes in the direction of the short ball when the arm is laid on the side.
- Align the hole in the radius link with the hole in the back of the washout-mixing arm. Press (1) radius link pin into each arm. Use a vise if necessary to press it in.

- Screw (1) M3x4 set screw into the back end of each arm. This will retain the pin. Use threadlocker.
- Press (2) 3x7x3F bearings into each washout-mixing arm. Make sure that the bearings are completely seated and that the flanges are flush.
- Fit (1) M3x16 special SHCS into the bearing holes from the outside of each washout-mixing arm. Put (1) M3 brass washer on the end of the screw sticking out the other side.
- Screw the assembly into the washout hub assembly. Face the pins in the washout hub up, one pin facing forward and one pin facing back. The washout mixing arms screws into the rear-most hole on the left side. Repeat with the other washout mixing arm assembly. Use threadlocker.
- Screw (1) M3x4 set screw into the other side of each hole in the washout hub assembly. This will act as a jamnut to keep the washout arm retaining screw from backing out. Use threadlocker.
- Adjust the screw for a slight bumpy or notchy feeling when moving the arm. Then tighten the setscrew. The freeplay should re-appear without slop. Adjust back and forth until smooth operation with no slop is obtained.
- Place the washout assembly onto the main shaft with the pins facing up.
- Snap each radius link onto one of the medium balls in the inner swashplate. The completed assembly will have the radius links 180 degrees apart on the swashplate.

SEESAW TUBE ASSEMBLY



39. Seesaw Tub Assembly

Part#	Qty	Description
1155	1	Seesaw Tube
3020	2	4x10x4 Bearing

- Press a 4x10x4 bearing into each end of the seesaw tube, double checking that you have the 4mm ID bearings, and not the 3mm ID bearings.. Be sure that the bearings are flush with the end of the tube. *Be sure that the bearings don't get cocked off line when pressing them in, or damage to the bearings and the seesaw tube will result.*

HEAD BLOCK

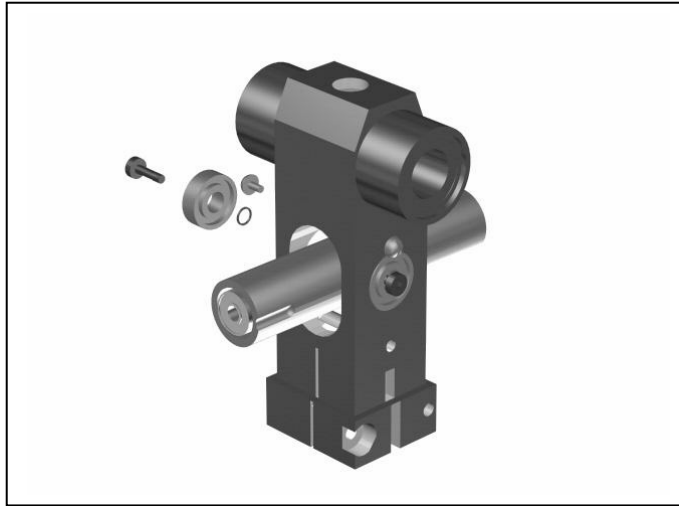

40. Head Block

Part#	Qty	Description
1105	1	Head Block
3015	2	3x10x4 Bearing
5155	4	M3 Brass Washer
5205	2	M3x5 Philips Pan Head Screw
5010	2	M3x8 SHCS
1160	2	Seesaw Endcaps
5095	2	3X4 Setscrews
5190	2	Short Balls

- Place the seesaw assembly in the head block with the groove on the ends of the tube trailing, as the head turns clockwise from the top.
- Make an assembly of (1) M3x8 SHCS, (1) 3x10x4 bearing, and (2) M3 brass washers.
- Using Permanent Thread Locker, place the assembly on the end of your Allen driver.
- Holding the head sideways, insert the assembly up in the bearing hole and into the threaded hole in the seesaw tube.
- Repeat for the other side.
- Use an (1) M3x5 Phillips Pan Head screw with removable thread locker, to hold the assembly in.
- Repeat for the other side.
- Adjust the screws so that the seesaw tube is centered in the head.
- Slide on and fasten the (2) seesaw end caps with (2) M3x4 set screws with removable thread locker, into the groove. *Make sure the end caps are flush with the ends of the seesaw tube.*
- Attach (2) short balls to each end cap post. Use threadlocker.



41. Head Axle

Part#	Qty	Description
1130	1	Head Axle
1135	4	Dampening O-ring
5030	2	M3x20 SHCS
1131	2	C-Clips

- Lubricate the head axle, dampening o-rings and the opening in the head block liberally with a high quality silicone grease.
- Insert head axle into head block and place 2 dampening o-rings on each end.
- Decide how much head dampening you want for your style of flying. In general, hot dog 3D types like a tight head, so install all 3 shims, the .008, .015, and the .040. For just general sport flying, a softer head might be better. In this case use only the .008 and the .040 shims. In any case, you **MUST** use the .040 shim at the very least. Ensure the same amounts of shims are installed on both sides.
- Now install the c-clips, pushing them all the way onto the head axle until they seat into the groove. You will have to compress the o-rings to get these into the grooves, use the blade grips if necessary to push the c-clip to the groove. Make sure the c-clip is seated, if it pops out in flight, it can cause vibrations in the rotor head.
- Insert (2) M3x16 SHCS into appropriate holes in bottom of head block. *Do not use threadlocker at this time.* These holes are the offset ones in the base used as pinch bolt holes.

BLADE GRIP ASSEMBLY

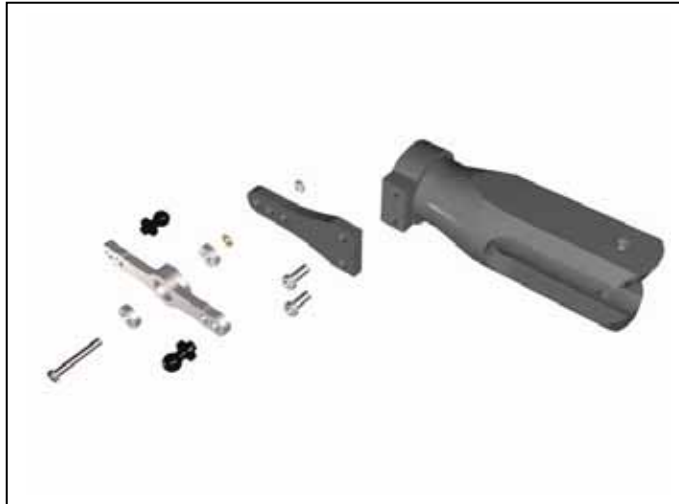

42. Blade Grip Assembly

Part#	Qty	Description
1151	2	Bell Mixer Arm
3086	4	3x7x3F Bearing
5190	4	Short Ball
5155	2	M3 Brass Washer
5136	2	M3x12 w/6mm Shoulder SHCS
5115	2	M3 Nut
1111	2	Blade Grip Assembly W/ Bearings Installed
1126	2	Blade Grip Pitch Arm
5005	4	M3x6 SHCS

- Assemble a blade grip pitch arm to the blade grip with 2 ea M3x6 SHCS. Use threadlocker.
- Press (1) 3x7x3F flanged bearing into each side of the bell mixer arm.
- (Note the bell mixer arms are not symmetric). Assemble (1) short ball into the outer most hole. (On the short side of the mixer arm facing out.)*
- Assemble (1) short ball to the outer most hole. *(On the long side of the mixer arm facing in.)*
- Attach the mixer arm assembly to the blade grip pitch arm with an M3x12 w6mm shoulder SHCS and M3 brass washer. Use threadlocker. *Use the middle hole on the blade grip pitch arm). Also attach a M3 hex nut on the end of the screw. This is used as a jam nut. Adjust the nut and screws for free movement of the mixer arms with minimal axial play and no notchy feeling in the bearing. Use threadlocker on the nut.*
- Repeat for other assembly.

BLADE GRIP ATTACHMENT



43. Blade Grip Attachment

Part#	Qty	Description
3006	2	8X16X5 Thrust Bearing
5072	2	M5x16 SHCS
5111	2	5x10x2 Spacer Washer

- Slide each blade grip assembly, with pitch arm leading for clockwise rotation viewed from the top, onto the head axle.
- Apply a high quality silicone grease to lubricate thrust bearing.
- Place an 8X16X5 thrust bearing on each end of the head axle. **Special Note: The larger ID race of the thrust bearing goes toward the head block. Use the head axle to determine the proper size race. (One will fit looser than the other.) There are different styles available. If you find all 4 races are the same, then it doesn't matter which one goes inboard.**
- Next, add (1) 5x10x2 washer and M5x16 SHCS. Use threadlocker.
- Tighten the two M5x16 SHCS tightly with two Allen wrenches, tightening both bolts at the same time.

FLYBAR

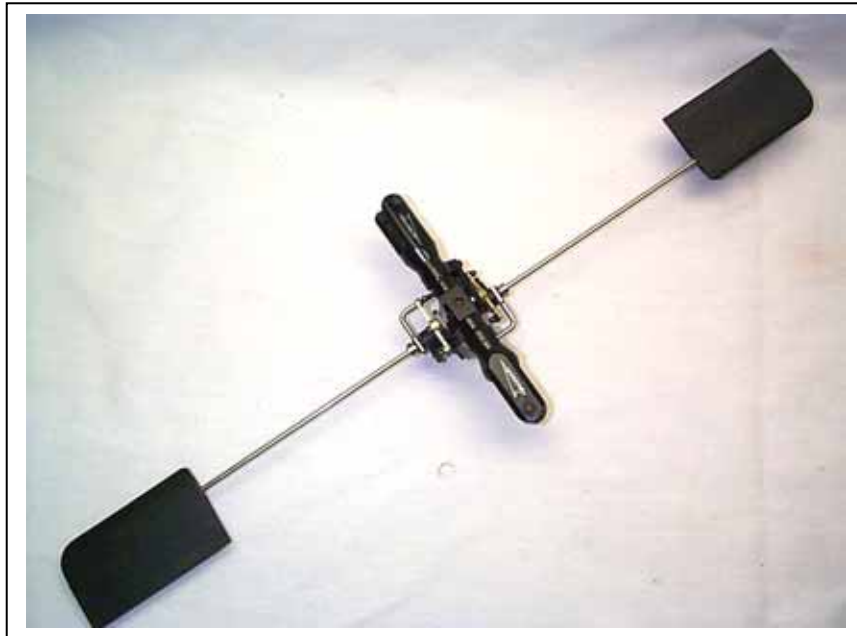

44. Flybar

Part#	Qty	Description
1711	1	Flybar
1175	2	Flybar Control Arm
5095	2	M3x4 Set Screw
1165	2	M4 Special Flybar Arm Washer
1181	2	Flybar Paddle

- Insert Flybar into seesaw.
- Place (1) M4 special flybar arm washer on each side followed by a Flybar control arm with ball leading for clockwise rotation, viewed from the top.
- Insert M3x4 set screws in each control arm and tighten after adjusting Flybar so it is exactly centered in the head and the arms are level with each other. Use threadlocker.
- Attach a Flybar paddle to each end of Flybar and turn until tight (minimum of 19 turns on) making sure they are equal distance from center, on the same plane as control arms, and leading edge forward for clockwise rotation.

HEAD ATTACHMENT

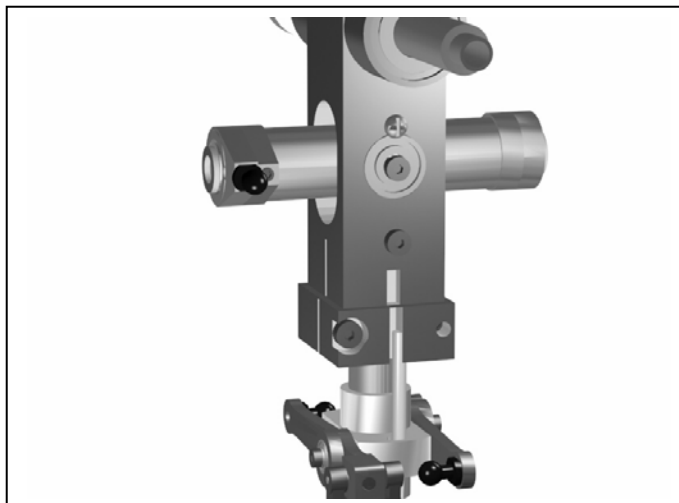

45. Head Attachment

Part#	Qty	Description
5035	1	M3x20 SHCS

- Place aluminum head block atop the main shaft.
- Align the follower pins in the slots in the head block.
- Align the hole in the head block above the slot with the hole in the end of the main shaft.
- Insert M3x20 SHCS “jesus” using threadlocker, but do not tighten yet.
- Tighten pincher bolts, alternating sides. Use threadlocker.
- Go back and tighten the “jesus” bolt.

HILLER PUSHRODS

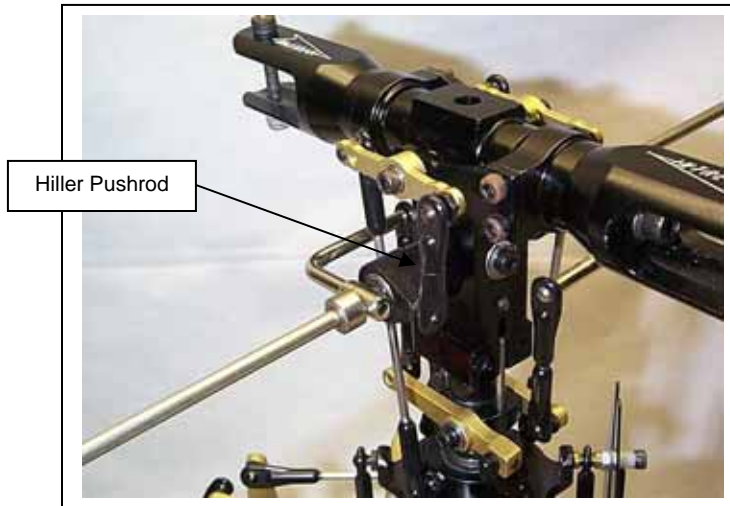

46. Hiller Pushrod

Part#	Qty	Description
1956	4	Ball Link 2.5mm
2025	2	Flybar Linkage Short 12mm

- Trim (4) Ball links to a length of 17mm from end to end.
- Thread (2) trimmed ball links onto (1) short flybar linkage – 12mm. Thread them on evenly so they share equal lengths of the linkage. Twist the completed link assembly 90 degrees. *The final length of the link assemblies will be 29mm from center of hole to center of hole.*
- Make a second link assembly to match the first.
- Snap one end of the link assembly onto the short ball of the bell mixing-arm. *The bell mixing-arm has unequal length sides. The shorter length side goes to this link assembly*
- Snap the other end of the link assembly onto the seesaw end cup short ball.
- Repeat the procedure on the other side of the head.
- If the links are tight on the balls, use a ball link sizing-tool to adjust the hole size in the links.

BELL PUSHRODS

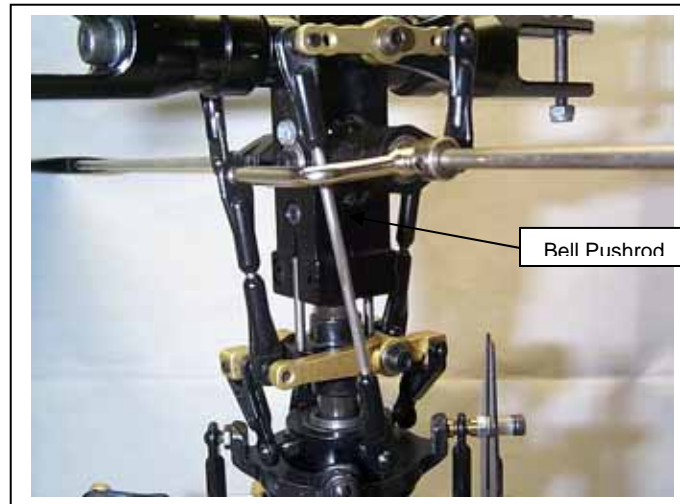

47. Bell Pushrods

Part#	Qty	Description
1956	4	Ball link 2.5
2020	2	Pitch Linkage 75mm

- Thread (2) ball links onto the pitch linkage. Thread them on equally.
- The final length of the link assembly will be 97mm from center of hole to center of hole.*
- Make a second linkage assembly, *and make sure that they are the same length. This is very important, as incorrect linkage lengths will lead to binding!*
- Snap (1) link assembly from the upper rotating portion of the swashplate (90 degrees to the washout links) to the other end of the bell mixing-arm. This is the longer end of the arm.
- Repeat on the other side of the head.
- If the links are tight on the balls, use a ball link sizing-tool to adjust the hole size in the links.

WASHOUT ARM LINKS

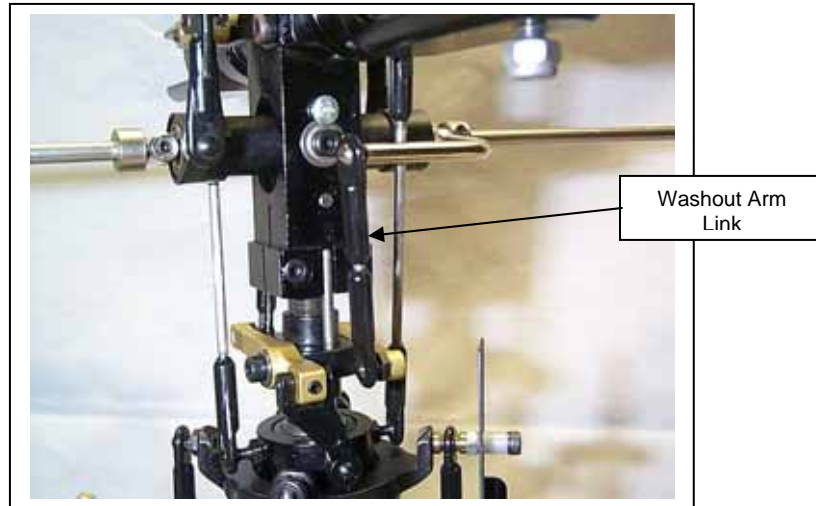

48. Washout Arm Links

Part#	Qty	Description
1956	4	Ball link 2.5
1995	2	Collective Linkage 30mm

- Thread (2) ball links onto the pitch linkage. Thread them on equally.
- The final length of the link assembly will be 47mm from center of hole to center of hole.*
- Make a second linkage assembly, *and make sure that they are the same length. This is very important, as incorrect linkage lengths will lead to binding.*
- Snap (1) linkage assembly onto the flybar control arm and onto one of the washout mixing arms.
- Repeat with the second link assembly on the other flybar control arm and the other washout mixing-arm. This second arm should have the ball positioned directly underneath the flybar control arm.
- If the links are tight on the balls, use a ball link sizing-tool to adjust the hole size in the links.

TORQUE TUBE



49. Torque Tube

Part#	Qty	Description
9015	1	Dogbone
9020	1	Dogbone Pin
5095	1	3x4 Set Screw (Dogbone)
109D	4	Collars
5094	12	3x3 Set Screw (Collar)
1000	1	Aluminum Tail Rotor Gear Box
2117	2	Arrow Drive Shaft
1171	1	Tail Boom

Trim the ends of the arrow shaft approximately one inch. Cut one arrow shaft to 16 ¼" and the other to 17" long

- Push the Dogbone Pin into the hole in the ball end of the Dogbone. Screw the 3x4 set screw into the other end of the dogbone (opposite the ball end) and tighten against the dogbone pin. Use threadlocker.

- Slip (1) Collar over one end of the shorter arrow drive shaft. Push the dogbone into the end of the shaft. Screw (3) 3x3 set screws into the collar at the three holes in the collar. Lightly tighten down the screws. Do not use threadlocker at this point.
- Once the dog bone is in place attach the other end of the shaft to the end of the 109-bearing carrier and secure with collar and setscrews. (Do not use thread locker at this time) Attach the remaining length of the arrow shaft to the other end of the 109-bearing carrier, again securing with the collar and setscrews.
- Slip the end of the tail rotor gearbox into the end of the drive shaft. Screw (3) 3x3 set screws into the collar at the three holes in the collar. Lightly tighten down the screws. Do not use threadlocker at this point.
- At this point remove one setscrew on each collar and using a small drill (#50) drill a hole through the arrow shaft creating a divot in the underlying shaft, so the setscrew will lock into the shaft. Now remove each setscrew, apply blue thread locker and reinstall all setscrews at this time, tightening securely.
- Lubricate the bearing carrier and slide the assembly into the boom.
- Attach the aluminum tail rotor gearbox to the end of the tailboom with (2) M3x4 SHCS. Use threadlocker. Do not overtighten these, but ensure they are secure.

TAILBOOM ASSEMBLY

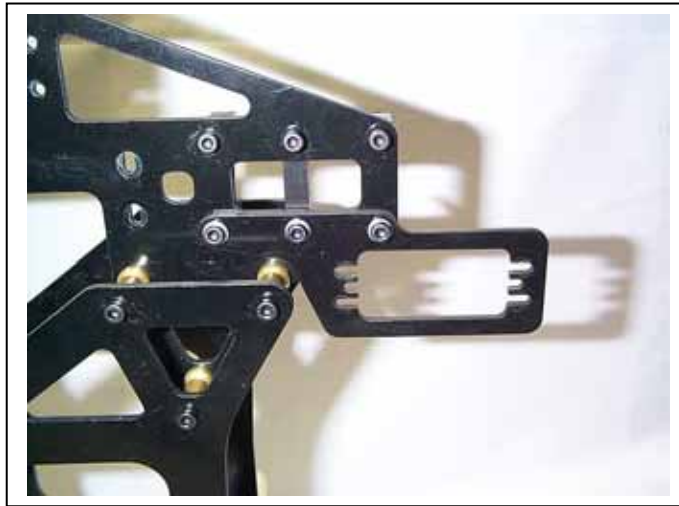

50. Tail boom Assembly

Part#	Qty	Description
5105	6	M3 Locknut
5110	6	M3 Washer
1535	1	Rudder Servo Mount
1667	1	Horizontal Fin Clamp

- Remove the (3) M3x40 SHCS located at the rear of the frames.
- Attach the rudder servo mount using the (3) M3x40 SHCS just removed, with (3) M3 locknuts. Do not tighten at this time.
- Attach (3) M3 locknuts to the (3) M3x35 SHCS protruding from the top tailboom clamp locations. Do not tighten at this time.
- Slide the horizontal fin clamp onto the tailboom and place it about $\frac{3}{4}$ back on the boom.
- Slide the front of the tailboom into the (3) tailboom clamps on the frames, and make sure that the universal joint (dogbone) slips into the delrin coupler.
- Push the tailboom forward until the dogbone bottoms out in the coupler. Pull back on the tailboom 1 mm. This is to relieve any rearward pressure on the tail drive train.
- Rotate the tailboom until the output shaft from the aluminum tail rotor gearbox faces out to the right and is perpendicular to the sideframes.
- Tighten the (6) M3 locknuts holding the (3) tailboom clamps sufficiently so that the tailboom cannot be pulled out the back with some force.
- Adjust the tail transmission block to obtain a good mesh with the main gear by pushing down on the front of the transmission cage. There should be minimal backlash between the tail drive pinion and main gear, but still spin freely.
- Tighten the (4) M3x10 SHCS holding the tail transmission block. Use threadlocker at this point. Also tighten the 3X35 SHCS and 3m nut securing the front of the transmission.

TAIL ROTOR GRIPS

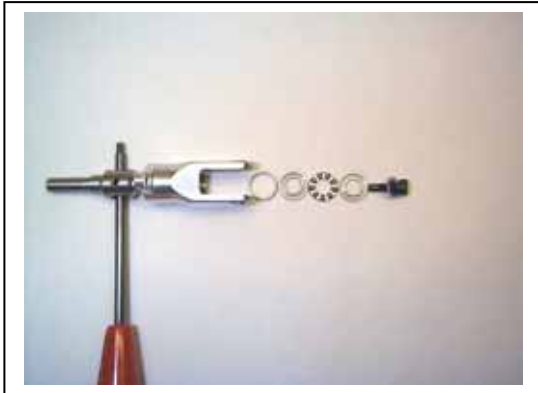

51. Tail Rotor Grips

Part#	Qty	Description
231	2	Tail Rotor Blade Grip Assembly
3052	2	5x10x4 Thrust Bearing
5112	2	M10 OD Spacer
5110	2	M3 Flat Washer
5005	2	M3x6 SHCS
Twin1815	1	Tail Rotor Main Hub M6

- The thrust bearing installs into the tail rotor blade grip assembly as follows: *Note: Each of these parts should be liberally greased with a high quality bearing grease before assembly.*
- Insert the 10mm OD spacer so it sits on the bearing in the grip.
- Insert the thrust-bearing race with the larger ID. *Note: Use the tail rotor main hub to size the thrust bearing races to find the larger ID.* The groove for the balls should be facing out.
- Insert the thrust bearing ball/cage assembly.
- Insert the thrust-bearing race with the smaller ID. The groove for the balls should be facing in.
- Repeat the above numbered steps with the other tail rotor blade grip.
- Slide the tail rotor blade grip assembly onto the tail rotor main hub. Attach each blade grip using a M3 X 6 SHCS and a M3 flat washer. Use threadlocker.

TAIL PITCH ASSEMBLY



52. Tail Pitch Assembly

Part#	Qty	Description
1960	1	Tail Pitch Slider
1961	2	Tail Special Ball Links
1806	2	Pivot Plate Arm Eyelet
1811	2	Pivot Plate Shoulder Bolt 4x4
5195	1	Medium Ball
5094	1	M3x4 Set Screw

- Attach 1 medium ball to the pitch slider assembly, if not already installed. Use threadlocker.
- Slide the tail pitch slider assembly onto the tailrotor output shaft with the pitch plate facing outward.
- Cut 1/8th of an inch off of the end of the special ball links, and trim the “rib” off as it may interfere with proper tail control.
- Screw the 2 tail special ball links to the (2) pivot plate arm eyelets.
- Attach each pivot plate arm eyelet and ball link onto each tail blade grip pivot arm using a pivot plate shoulder bolt. The eyelet and ball link should go on the side of the arm facing the center of the tail rotor main hub. Use threadlocker.
- Slide the tail rotor main hub assembly onto the tail output shaft. Align the hole in the tail rotor main hub with the indentation on the tail output shaft. Secure with a M3 X 4 setscrew. Use threadlocker. Use only ONE setscrew on the tail hub.
- Snap the ball links onto the balls on the pitch slider.
- Test the sliding action of the completed pitch assembly. It should move freely. You may have to unscrew one of the ball links slightly to align it properly to the ball.

PITCH BELLCRANK

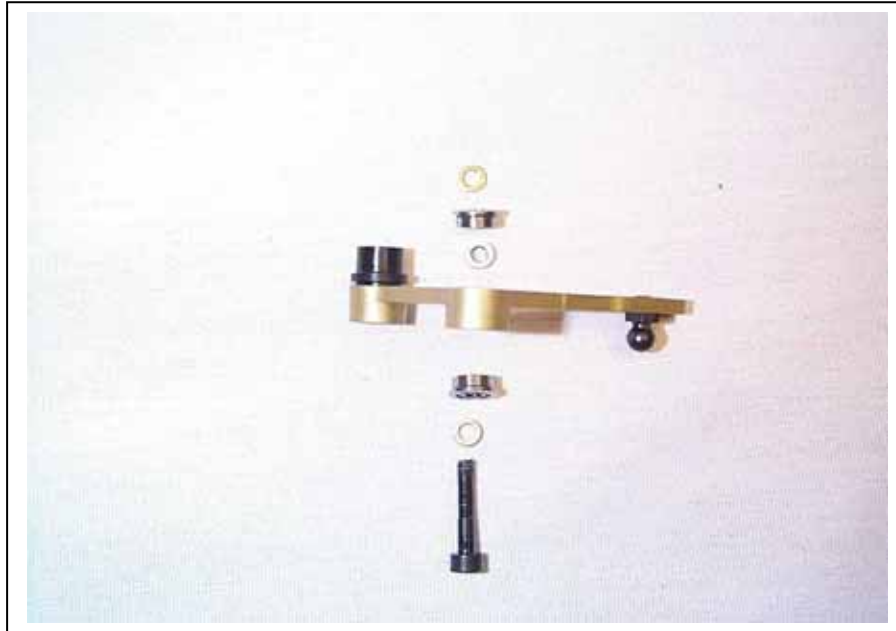

53. Pitch Bellcrank

Part#	Qty	Description
240B	1	Bellcrank
240A	1	Delrin Insert
240C	1	Aluminum Spacer
3086	2	3x7x3 Flanged Bearing
5140	1	M3x16 w/6 Shoulder SHCS
5155	2	M3 Brass Washer
5195	1	Medium ball
5105	1	M3 Locknut

- Position the Bellcrank as shown in the picture. Screw the medium ball into the innermost hole, facing down. Use threadlocker.
- The delrin insert should be pre-assembled onto the bellcrank, but if not, then screw the insert into the bellcrank from the top.
- Press (2) 3x7x3 flanged bearings into the bellcrank, 1 from each side, with the aluminum spacer in the middle, between the bearings.
- Install the 3X16 w/6 shoulder through the bearings and put a brass washer on the screw sticking up from the top of the upper bearing.
- Screw the assembly into the pitch arm bracket while fitting the medium ball from the pitch slider into the delrin insert.
- Tighten the screw while checking for binding on the bellcrank. It should be just snug without binding or any up and down play. If it binds, add another brass washer in the middle, between the bearings, to keep the bearings moving free. If there is up and down play, sand the aluminum spacer slightly to achieve smooth movement with no slop.
- Screw on the M3 Locknut from the top onto the protruding screw to act as a jamnut. Check again for proper movement of the bellcrank.

TAIL BLADES

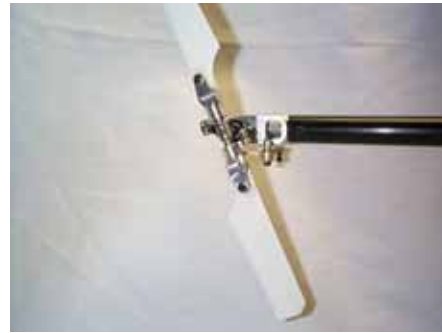

54. Tail Blades

Part#	Qty	Description
231B	4	Blade Grip Spacer
5146	2	M3x19 w/11 Shoulder SHCS
5105	2	M3 Locknut
6015	2	Tail Rotor Blades

- Mount (2) tail blades to blade grips using (4) blade grip spacers, 2 M3 X 19 shoulder SHCS and (2) M3 nylon locknuts. 1 spacer goes on each side of the tail blade and in turn goes into the blade grip.
- While facing the side of the tailboom with the tail pitch mechanics, the tail rotor spins counterclockwise. Make sure that the leading edges of the tail blades face in the counterclockwise direction.
- Tighten the tail blade bolts so that the friction *just* holds the blades in position when turning the tail rotor. *Do not overtighten.*

RUDDER SERVO



55. Rudder Servo

Part#	Qty	Description
1947	2	Plastic Servo Mount Tabs
5137	1	M2x5 Ball
5207	1	M2x10 PHSMS
5120	2	M2 Nut

- Prepare the servo with the hardware provided with the radio system: install the rubber grommets on the servo mounting ears, and then install the brass eyelets into the grommets up from the bottom of the servo ear. Use self-tapping screws provided by the radio system for mounting the servos to the tray, or use M2.5x15 SHCS (*not provided in kit*). Use the plastic servo mounting tabs as nuts. Screw the screws into the tabs, holding the tabs from the inside of the mount as it is screwed in. Mount the servo in the rudder servo mount such that the output shaft is toward the rear and facing to the right of the machine. The arm should be pointing straight down when centered.
- When tightening the screws, be sure to get the servo tight enough that it can't move, but do not squeeze the rubber grommet so much that the isolating properties of the grommet are lost. The servo should be able to rock from side to side slightly when tightened. Paying attention to this important note will increase the lifetime of the servos.*
- Setting up the tail control system starts in your radio. Turn off all mixes, 0 out all subtrims, set stick trims to neutral. Anything that can affect how the tail operates should be shut off or neutralized. Some radios come with these things turned ON by default.

Turn your radio on, making sure the switch that you use for turning heading hold on and off is set to ON. The Gyro must initialize in heading hold.

Turn the helicopter on, looking at the gyro. When the light stops blinking and goes steady red on, then the gyro is initialized properly.

Now turn the heading hold function OFF, using the switch that you designated on your radio.
The light on the gyro will go off.



- Use the smallest wheel that comes with the servo,
- Put the ball on the M2x5 PHSMS screw, followed by a M2 nut. Use threadlocker, but sparingly.
- Install this assy into the hole that is straight down from the servo spline, as seen in the picture.
- Put another M2 nut on the backside of the arm on the screw. Use threadlocker, sparingly.
- Install the wheel onto the servo, not forgetting the servo screw. More than one heli has been lost due to forgetting to install it!



The ball on the tail bellcrank should be in the inner most position.



Looking at the tail pitch slider, it should be centered by adjusting the length of the carbon fiber pushrod.



Now give full rudder stick deflection, checking that the throw is equal on both sides. If it bottoms out in either direction, reduce the travel amount on the gyro. If the throw is not equal on both sides, ensure the slider is centered (adjust the pushrod), and setup in the radio is as described above.

Now adjust the travel amount on the pot on the gyro itself to between 100 and 120. This should give full travel on the slider without binding at the gearbox or tail hub.

Set the pirouette rate (how fast it spins) in your radio using the rudder ATV. Start at 80% and work your way up.

Set the gyro gain at 80% in heading hold, 70% in non-heading hold, to start with. I have been able to get as high as 110% on my gasser using the green anti vibration gel from Zeal.

Check servo direction and gyro direction before flying, it gets real exciting when it's backwards! 🤖

After getting the engine tuned in close, and the main blades tracked, hover the heli with the

heading hold turned OFF. The heli will probably drift one way or the other.



To trim out this drift, **DO NOT** adjust the carbon fiber pushrod. Instead, adjust the length of the plastic ball links between the pitch slider and the tail blade grips. Turn them both equally to maintain tail blade tracking. When the drift is trimmed out, turn heading hold on and go fly!! The tail will be locked in, and should not overheat the servo.



There is a push-pull rudder upgrade available. It consists of a ball bearing push-pull arm and all the hardware necessary to upgrade the machine to a full push-pull control system. Contact Bergen R/C for details.

We do not recommend the push pull setup for the Futaba 401 gyro.

TAILBOOM SUPPORT STRUTS



56. Tailboom Support Struts

Part#	Qty	Description
1710	2	Tailboom Support Struts
1715	4	Tailboom Support Strut Ends
5015	2	M3x10 SHCS
5050	1	M3x35 SHCS
5105	3	M3 Locknuts

- Temporarily insert the (4) support strut ends into the (2) tailboom support struts.
- Mount one end of each of the support struts onto the bottom of the fin clamp using an M3x35 SHCS and a M3 locknut. *Do not tighten at this time.* One strut goes on each side of the fin clamp.
- Mount the other end of each tailboom support strut to the bottom of each lower sideframe using (2) M3x10 SHCS and (2) M3 locknuts. The support strut end goes on the inside of the sideframe and the locknut goes on the outside. *Do not tighten at this time.*
- Align the top of the fin clamp perpendicular to the main frames. Check to make sure that all support strut ends are inserted all the way into the tailboom support struts. This is a "dry fit" of the struts. Verify alignment and tighten all screws.
- Mix up some JB Weld Epoxy to permanently attach the support strut ends to the tailboom support struts. Remove one strut at a time, clean the strut end and the strut with alcohol, dry, apply the glue and re-assemble to be sure alignment is maintained.
- Let cure overnight.

RUDDER PUSHROD



57. Rudder Pushrod

Part#	Qty	Description
251	1	Push Rod Carbon Fiber
1983	2	Pushrod Ends
1956	2	Ball Link 2.5
5030	2	M3x20 SHCS
5105	2	M3 Locknut

- Push (1) M3x20 SHCS through the open end of (1) Pushrod End. Screw (1) M3 Locknut onto the threaded end sticking out until tight.
- Thread (1) ball link onto the threaded end about $\frac{3}{4}$ of the way on, to allow for adjustment in both directions.
- Repeat with the other pushrod end assembly.
- Snap (1) pushrod assembly onto the tail pitch bellcrank.
- Snap the other pushrod assembly onto the rudder servo arm ball.
- Adjust the tail pitch bellcrank so that the tail pitch slider is centered on the tail output shaft.
- Make sure that the rudder servo arm is pointing straight down, perpendicular to the tailboom.
- Hold the carbon fiber pushrod up in position next to the two pushrod ends. Measure and cut the carbon pushrod so that it will fit all the way into the pushrod ends with everything positioned previously.
- Mix up some JB Weld Epoxy to permanently attach the pushrod ends to the carbon fiber pushrod. Clean the pushrod end and the pushrod with alcohol, dry, apply the glue and re-assemble to be sure alignment is maintained.
- Let cure overnight.

FINS

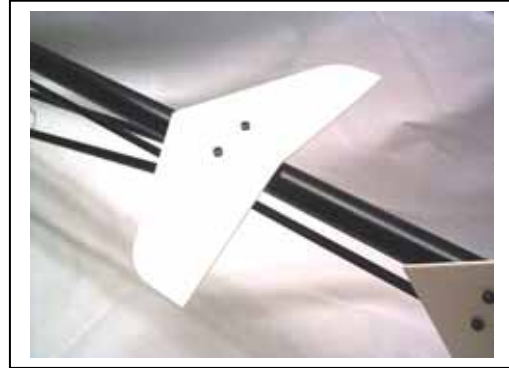

58. Fins

Part#	Qty	Description
1665	2 Sets	Tailboom Clamps
5010	2	M3x8 SHCS
5050	4	M3x35 SHCS
5105	4	M3 Locknuts
1832	1	Vertical Fin
1835	1	Horizontal Fin

- Attach the horizontal fin to the fin clamp that was previously installed onto the tailboom. Use (2) M3x8 SHCS. The horizontal fin should be perpendicular to the sideframes. You may need to loosen the fin clamp bolt to get the fin mounting bolts started. Then tighten the fin clamp.
- Mount the vertical stabilizer using (2 sets) of tailboom clamps, (4) M3x35 SHCS, and (4) M3 locknuts. Place one of the tailboom clamps just behind the tail gearbox mounting screw, and one in front of the mounting screw.
- Slip the (4) M3x35 SHCS through the 4 holes in the vertical fin and the 2 sets of tailboom clamps. Attach (4) M3 locknuts to the ends of the screws. Do not tighten yet.
- Make sure that the vertical fin is parallel to the sideframes and perpendicular to the horizontal fin. Now tighten the screws and nuts.

FUEL TANK

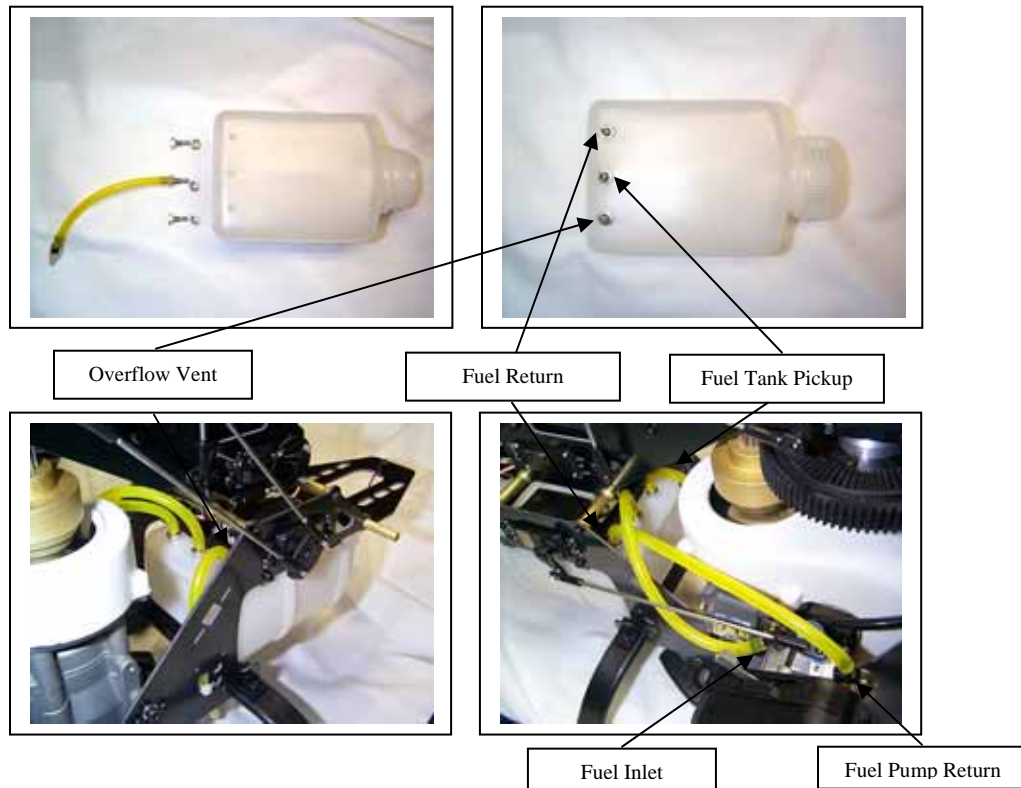

59. Fuel Tank

Part#	Qty	Description
1880	1	Fuel Tank
1850	1	Clunk
1855	2	Single End Fitting
1860	1	Double End Fitting
1865	3	Fuel Tank Nuts
1870	1	Fuel Tubing

- Drill (3) 3/16" holes about 1/2" from the closed end of the tank, all on the same face of the tank, on the centerline with that face, about 1" apart with the center hole on the centerline of that face.
- Deburr each hole, both on the inside and the outside of the tank.
- Insert (1) Single End Fitting in one of the end holes on the inside. A long, skinny hemostat forceps works well for this. Screw (1) Fuel Tank Nut on the outside of the tank on the threaded nipple sticking out from the hole. Be sure to get the nut tight to make a good seal. Repeat with the second end hole.
- Cut a piece of fuel tubing about 4 3/8" long. Push one end onto the clunk. Push the other end on the Double End Fitting, on the *non-threaded* end. This length is approximate, as the final length may need adjusting slightly to get proper clunk operation.

- Insert the Double End Fitting into the center hole in the tank, from the inside. Screw (1) Fuel Tank Nut on the outside of the tank on the threaded nipple sticking out from the hole. Do not tighten at this time. This is a trial fit only. This is the fuel pickup side of the tank.
- Check for correct clunk operation by tipping the tank in various orientations to make sure the clunk reached as far as it can, but does not get hung up on the end or sides of the tank. Adjust the fuel line length as necessary.
- Insert the tank into the opening in the lower side frames from the front of the machine. The end with the fittings goes in first. The fittings should fit up in back of the rear of the radio tray.
- Put the lid on the tank and tighten.
- Connect a piece of fuel line tubing onto the center pickup line of the tank. Connect the other end of the fuel line to the carburetor fuel inlet furthest away from the little fuel bulb on the carb.
- Connect a piece of fuel tubing onto the left-hand side fitting of the tank. Connect the other end of the fuel line onto the other carburetor fitting (the one next to the little fuel bulb on the carb. This is the return overflow for the fuel pump in the carb.
- Connect a small piece of fuel tubing on the remaining fitting on the tank, and run it down below the bottom of the lower sideframe. This the overflow vent for the tank.

When fueling the machine, disconnect the fuel line from the return fitting on the carburetor and fuel through the line into the tank. Fill until the fuel almost comes out the top of the overflow vent of the tank, then reinstall the fuel line onto the return fitting. Pump the bulb, drawing fuel to the carb, until solid fuel runs back through the return to the tank.

CANOPY



60. Canopy

Part#	Qty	Description
1921	1	Canopy - Lexan
1945	4	Canopy Grommet
1946	4	Thumb Screws

Your canopy may differ in shape, but the assembly is the same.

- If canopy is to be painted on the inside, leave the blue plastic coating on the outside of the canopy halves until finished painting. This will add protection should any over spray get on the outside of the canopy.
- Prepare canopy halves by washing in warm soapy water to remove grease and finger oils. Dry completely.
- When painting, use a good quality paint that will adhere to the lexan and be fuel proof. One method is to use lacquer based R/C car body paints, such as Pactra lexan paint on the inside of the canopy, followed by a fuel proofing coat of polyurethane for protection. A good suggestion is Top Flite Luster Kote. It will not attack the lacquer color coats. A paint that remains flexible is preferred, as the lexan can flex quite a bit.
- Trim around the outside of the canopy halves with scissors. Lexan scissors for the R/C car bodies works well. Where the 2 halves come together, leave about ½ inch. In the open areas, leave about ¼ to 3/8 inch of lexan past the bends that are the edges of the canopy.
- Glue the 2 halves together using a good glue that remains flexible, such as Pacer Zap A-Dap-A Goo II or Shoe Goo. Use clothes pins to hold the halves together in place until completely dry.
- Remove the clothespins and trim the glued edges to about ¼ inch.
- Use some excess lexan to reinforce the areas at the bottom and top of the canopy where the 2 halves separate and open up in the back. This will add strength and resist vibration.
- Locate the canopy on the helicopter, trimming where necessary to clear pushrods and such. When happy with the location, use a flashlight shining on the inside of the canopy to locate the mounting studs, drilling a 1/8th hole and installing the canopy screw. Repeat for other three mounting locations. When you're happy with these locations, open up the hole to 5/16th and install the rubber grommets, securing them on the inside with a drop of CA glue.
- Now install the canopy using the canopy thumbscrews.

FINAL ADJUSTMENTS

The two aileron pushrods should be adjusted so that with no control input, the rear-most balls on the bell cranks are positioned directly over the pivot point for the transverse lever. This will place the horizontal arms on these bell cranks parallel with the collective levers. Since these pushrods attach to the servo at an angle from either side, in order to achieve equal movement on the aileron control, the balls on the aileron servo arm should have been offset forward, per the drawings.

Now its time to adjust the elevator control system. The pushrod-to-servo adjustment should be accomplished with the same procedure we used on the collective servo. When positioning the servo arm on the elevator servo, it should be placed on a spline so that when the servo is in neutral, the upper elevator bell cranks balls (the unused ones at this time) are vertical. This will determine the elevator trim. The two pushrods should then be attached to the rear of this top bell crank, and back to the elevator lever. Each of these pairs of pushrods should be of equal length (two different lengths, but two matched pairs). Once these are adjusted to equal length, they should **NEVER** be adjusted further.

These are not the linkages to use to mechanically trim the helicopter. If they are not of equal length, binding will occur at some point in their movement.

One thing to keep in mind here, these two sets of pushrods are NOT ADJUSTED except to make them equal. The servo arm on the elevator must be positioned on a spline that will allow the final elevator lever to be parallel to the main shaft.

Now it is time to adjust the four pushrods that support the swash plate. All four of these pushrods should be of identical length. These pushrods should be adjusted so as to give your swash plate equal movement up and down, as the collective lever is moved to each extreme. If your Intrepid needs any trim adjustments that cannot be accomplished from the transmitter, these are the pushrods that should be adjusted.

The pushrods that attach the hiller levers (flybar control arms) to the washout levers should, of course, be of identical length. A “generic” length was given before, and it will work well. If you are going to maximize every control on your Intrepid for 3D style aerobatics, you can also shorten these two pushrods slightly (they **MUST** remain equal in length). This will allow the washout levers to be slightly higher throughout the collective range, and allow a small increase in cyclic travel at extreme positive collective.

Now, it's on the one of the most crucial adjustments on your helicopter, although it's one of the easiest to achieve correctly. The bell-hiller mixers that are attached to the blade holders should be perfectly horizontal in the center of your collective range. If this is adjusted correctly, your Intrepid will always have the same “feel” when flying, no matter where the collective is. The bell pushrods (they go from the swash plate to the bell-hiller mixer), and the hiller pushrods (the short ones from the flybar seesaw to the mixing arm), should be adjusted so that at “neutral” collective the bell-hiller mixer is exactly horizontal. What this means is that if you want to have a total pitch range of plus 10 degrees to minus 10 degrees, the bell-hiller mixers should be horizontal at 0 degrees pitch. If you are a beginner, these mixers should be horizontal at a pitch setting of +5 degrees, with ten degrees being maximum pitch and 0 degrees being minimum pitch.

The throttle linkage should be set so that at 50% throttle movement the pushrod is at a 90-degree angle both at the servo arm and at the throttle lever on the engine. The length of the throttle servo arm should then be made just long enough to achieve full opening of

the carburetor, and full closing of the carburetor with the throttle trim in it's lowest position.

ENGINE BREAK-IN AND FLIGHT OPERATIONS

Engine break-in should be done carefully with the proper mix of fuel and oil. Fresh 87 Octane gasoline should be used. Use a high quality full synthetic 2 stroke oil, such as Yamalube R or Morgan Synthetic oil. Mix 6 oz. Of oil per 1 gallon of gasoline. Use this mixture ration for the first two gallons. After that, the oil can be reduced to 5 oz. Per gallon. Adjust the low speed needle on the carburetor (marked L) 1 3/8 turn from closed. Adjust the high speed needle (marked H) 1 3/8 turn from closed. These settings are a start and may need slight adjustment from there, but will get the engine running and flying safely.

Your Bergen Intrepid Gas Helicopter should hover at appx 5 degrees of pitch, and at a headspeed of 1450 RPM. For aerobatics, you can take the headspeed up to 1750, but a good RPM would be around 1650-1700.

We recommend using PCM radio systems and a base loaded antenna such as the Revolution brand from Horizon Hobbies.

We also recommend setting the failsafe feature in modern PCM radios so that the engine either goes to idle or shuts off in the event of an interference lockout. This may help to save your helicopter if the interference stems from your engine, ignition, or drive train by reducing or eliminating the source of the interference, allowing you to safely auto and land the helicopter.